

Single-phase Microinverter

USER MANUAL

HMS-300W-1T
HMS-350W-1T
HMS-400W-1T
HMS-450W-1T
HMS-500W-1T

Legal Notice

Hoymiles has made every effort to ensure the accuracy and completeness of this manual. However, this manual may be changed and revised due to product enhancements or user feedback.

Hoymiles reserves the right to modify this manual without prior notice at any given time. The latest version of this manual can be found by visiting the Hoymiles official website (www.hoymiles.com) or scanning the QR Code below.



Emission Compliance

This equipment has been tested and found to comply with the limits applied by the local regulations. These limits are designed to provide reasonable protection against harmful interference in a residential installation. This equipment generates, uses, and can radiate radio frequency energy and, if not installed and used in accordance with the instructions, may cause harmful interference to radio communications. However, there is no guarantee that interference will not occur in a particular installation. If this equipment does cause harmful interference to radio or television reception, which can be determined by turning the equipment off and on, you are encouraged to try to correct the interference by one or more of the following measures:

- Reorient or relocate the receiving antenna.
- Increase the separation between the equipment and the receiver.
- Connect the equipment to an outlet on a circuit different from that to which the receiver is connected.
- Consult the dealer or an experienced radio/TV technician for help.

** Changes or modifications not expressly approved by the party responsible for compliance may void the user's authority to operate the equipment.*

Warranty

Follow the installation instructions in this manual to ensure warranty compliance and reliability. The current warranty conditions can be accessed at www.hoymiles.com.

Contact Us

If you have technical queries or any questions concerning our products, please contact our support through the Hoymiles service portal:

**Germany**

service.de@hoymiles.com

Spain

service.es@hoymiles.com

France

service.fr@hoymiles.com

Italy

service.it@hoymiles.com

Netherlands

service.nl@hoymiles.com

Rest of the EU

service.eg@hoymiles.com



+31 852736388 (English, German, French, Polish, and Dutch Support)



[hoymiles.com](http://www.hoymiles.com)

Using This Manual

Symbols

•	List
▷	List (second level)
Step 1, Step 2, ...	Installation steps in a defined order
A), B), C) ...	Installation steps in a defined order (second level)

Abbreviations

Abbreviation	Meaning	Abbreviation	Meaning
AC	Alternating Current	PE	Protective Earthing
AP	Access Point	PPE	Personal Protective Equipment
DC	Direct Current	PV	Photovoltaic
MPPT	Maximum Power Point Tracking	SN	Serial Number
O&M	Operations and Maintenance		

Related Documents

The following documents have been produced to assist you in maximizing the microinverter's potential.

Datasheet	<i>Datasheet HMS-500W Series EU EN</i>
Quick Installation Guide	<i>Quick Installation Guide HMS-500W Series EU EN</i>
Tutorial Videos	<i>Installation Video HMS-500W Series Global EN</i>
Others	<i>Hoymiles Compatibility Calculator</i>

Revision History

V20240709	This issue marks the initial official release.
-----------	--

Contents

1	About This Manual	1
1.1	Purpose	1
1.2	Audience	1
1.3	Validity	1
2	Safety Instructions	2
2.1	Safety Symbols	2
2.2	Additional Symbols	2
2.3	Safety Instructions	3
3	Product Information	5
3.1	Overview	5
3.2	Appearance and Dimensions	8
4	Installation Steps	9
4.1	Preparation	9
4.2	Single-Microinverter System	12
4.3	Multi-Microinverter System	15
5	Setting Up and Activating Monitoring	21
5.1	Direct Connection	21
5.2	Remote Connection	23
6	Troubleshooting	26
6.1	Troubleshooting List	26
6.2	LED Indicator Status	28
6.3	AP Password Troubleshooting	28
6.4	Wireless Network Troubleshooting	29
6.5	On-Site Inspection and Maintenance Instructions (Only for Qualified Technicians)	30
7	Decommission	31
7.1	Removing the Microinverter	31
7.2	Replacing the Microinverter	31
7.3	Storing and Transporting the Microinverter	32
7.4	Disposing of the Microinverter	32
8	Technical Data	33
9	Installation Map	34
10	Appendix 1: WIRING DIAGRAM	35

1 About This Manual

1.1 Purpose

This manual provides information on the installation, electrical connections, operation, and maintenance of the HMS-500W-1T series microinverters.

Please consider the following before installation:

- Carefully read this manual before operation.
- Keep this manual for reference.

1.2 Audience

This manual is intended for use by qualified persons only. Qualified persons must have the following skills:

- Understanding of microinverter operations and related functionalities.
- Knowledge of microinverter installation, usage, and maintenance.
- Competence in handling risks linked to microinverter installation, usage, and maintenance.
- Familiarity with local electrical codes and regulations.

1.3 Validity

This manual is valid for:

Model	Output Power (VA)
HMS-300W-1T	300
HMS-350W-1T	350
HMS-400W-1T	400
HMS-450W-1T	450
HMS-500W-1T	500

NOTE

Model identifier:

HMS-500W-1T
— T — T T T
A B C D

[A]: Series Name

[B]: Output Power Level





[C]: Features (built-in Wi-Fi module)

[D]: Number of Inputs

2 Safety Instructions







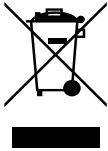

2.1 Safety Symbols

Safety symbols are used in this manual as follows:

Symbol	Description
 DANGER	This symbol indicates potential risks that, if not avoided, may lead to death or serious physical harm.
 WARNING	This symbol indicates potential risks that, if not avoided, may lead to personal injury or device damage.
 CAUTION	This symbol indicates potential risks that, if not avoided, may lead to device malfunctions or financial losses.
NOTICE	This symbol indicates potential risks that, if not avoided, may lead to minor injury or damage to the equipment.
 NOTE	This symbol indicates an important step or tip that leads to the best results but is not safety or damage-related.

2.2 Additional Symbols

The product label contains the following symbols with their meanings described below:

Icon	Explanation
	Treatment Electrical equipment that has reached the end of life must be collected separately and returned to an approved recycling facility to comply with the European Directive 2002/96/EC on Waste Electrical and Electronic Equipment and its implementation as national law. Return any devices you no longer need to an authorized dealer or an approved collection and recycling facility.
	Risk of Electrical Shock
	High Voltage Microinverters may contain high voltages, causing a risk of death.
	Danger Refer to safety instructions.
	Hot Surface The microinverter may become hot during operation. Do not contact with metal surfaces.
	CE mark The microinverter conforms to the Low Voltage Directive of the European Union.
	FCC mark The microinverter complies with the FCC standard.
	Read the manual first Read this manual carefully before performing any installation, operation, or maintenance.

2.3 Safety Instructions

The HMS-500W-1T series microinverters have been designed and tested in compliance with international safety standards, and thus require careful installation and operation. Installers must carefully read and strictly follow the safety instructions in this section. Failure to do so may result in:

- Injury or death to the installer or operator
- Damage to the microinverter

DANGER!

General

- All installation, start-up, troubleshooting, maintenance, and all other operations must be performed by a licensed electrician and follow local wiring codes.
- Always use personal protective equipment (PPE), like gloves and goggles, during installation.
- The microinverter should only be used when all technical parameters are observed and applied correctly. (You can refer to "[Technical Data](#)" for more details.)

Installation & Operation

- Report any non-standard installation conditions to the manufacturer.
- Do not install the equipment in flammable, explosive, corrosive, extreme heat/cold, or humid environments.
- Each microinverter input should only be connected to a single PV module. Do not connect batteries or other power supply sources. The unsupported devices have different output characteristics that differ from PV modules, potentially leading to improper functioning of the microinverters and posing safety hazards.
- Do not use the equipment in environments where safety devices are not working properly.
- Do not use the equipment if any unusual operations are detected.
- Check and ensure that all AC and DC wiring is properly installed and free from any snags, shorts, or damage. Additionally, ensure that all AC distribution boxes are securely sealed.
- Hoymiles shall not be liable for any damages caused by incorrect or improper operations.

Maintenance & Repair

- Ensure that the DC connectors are in perfect condition and that none of the DC conductors are exposed.
- Do not attempt to repair the product. All repairs must be done by licensed contractors or authorized Hoymiles service representatives using approved spare parts installed according to their intended use.
- Prior to any maintenance and repair operation, disconnect the power supply. Do not disconnect the AC and DC connectors under load.
- Maintain extreme caution when the microinverter is disconnected from the public grid. Hazardous voltages may still be present in some components.

WARNING!

General

- Disconnect the microinverter from the electrical power supply before making or modifying any device connections.
- Restrict product access by unauthorized individuals.

Installation & Operation

- Make sure to obtain all necessary approvals from local power operators before connecting the microinverter to the power grid.

- To protect from rain, UV, and adverse weather conditions, install the microinverter beneath the PV module. Avoid exposing the AC and DC connectors to rain or moisture prior to connection.
- Use the [Hoymiles Compatibility Calculator](#) to verify the electrical compatibility of PV modules. To maintain the Hoymiles warranty, only use Hoymiles microinverters with the compatible PV modules shown on the Hoymiles Compatibility Calculator.
- Make sure that the PV module's maximum open circuit voltage falls within the maximum DC input voltage for the microinverter. (You can refer to "[Technical Data](#)" for more details.)
- Improper use, incorrect installation, or unauthorized removal of necessary protections may result in damage to the equipment or serious safety and shock hazards.
- Microinverter surfaces can reach high temperatures during operation and for a short time after switching off the AC circuit breaker. Avoid direct contact with these surfaces.

Maintenance & Repair

- Avoid immersing the cable connectors or cables for a long period.
- Prevent any contaminants or deposits from entering the connector.
- Equipment repairs should only be performed by the Hoymiles Service Team, a repair team authorized by Hoymiles, or by authorized personnel familiar with all warnings and operating procedures contained in this manual.
- Ensure that the installation surface and equipment are within safe temperature and voltage ranges prior to handling any part of the microinverter.

CAUTION!

Installation & Operation

- Before installation, inspect for transportation damages compromising insulation integrity and safety clearances.
- Do not remove or cover any warning labels or nameplates on the microinverter.
- Lift the microinverter carefully. Take the weight of the microinverter into account.
- Follow the wiring safety instructions to ensure proper polarity and secure connections.
- Inspect the microinverter system for functionality and performance post-installation. Double-check the electrical connections, communication links, and monitoring features.

Maintenance & Repair

- The microinverter packaging has been intentionally designed to be reusable. Retain the packaging for future use.
- Do not clean the equipment with filamentary or corrosive material-based rags to prevent corrosion and electrostatic charges.

3 Product Information

3.1 Overview

Functions

Microinverters are module-level power electronics that convert direct current (DC) into alternating current (AC). The HMS-500W-1T series microinverters are designed for smaller budgets and compact residential installations. It's a single-phase unit that comes with a built-in Wi-Fi module, allowing it to communicate directly with the S-Miles Cloud platform, so you don't need an extra data transfer unit (DTU).

Features

- Maximum output power up to 300/350/400/450/500 VA
- Independent Maximum Power Point Tracking (MPPT) technologies, keeping your solar power always on
- Built-in industrial+ grade Wi-Fi module for high reliability
- Hassle-free assembly with a user-friendly plug-and-play design
- Maximum efficiency 96.7% in overcast weather
- Adjustable power factor, supporting 0.8 leading and 0.8 lagging
- Enhanced safety with rapid shutdown compliance and isolated transformer
- Durable and reliable IP67 enclosure, 6000 V surge protection

Applications

The HMS-500W-1T series microinverters can work in two types of systems: single-microinverter system and multi-microinverter system.

In a single-microinverter system, the whole system includes one microinverter and one PV module. This setup is great for places like balconies or outdoor areas with lots of sunlight, like gardens or front lawns.

In a multi-microinverter system, you'll have multiple microinverters, each paired with one PV module. These setups are usually found on rooftops.

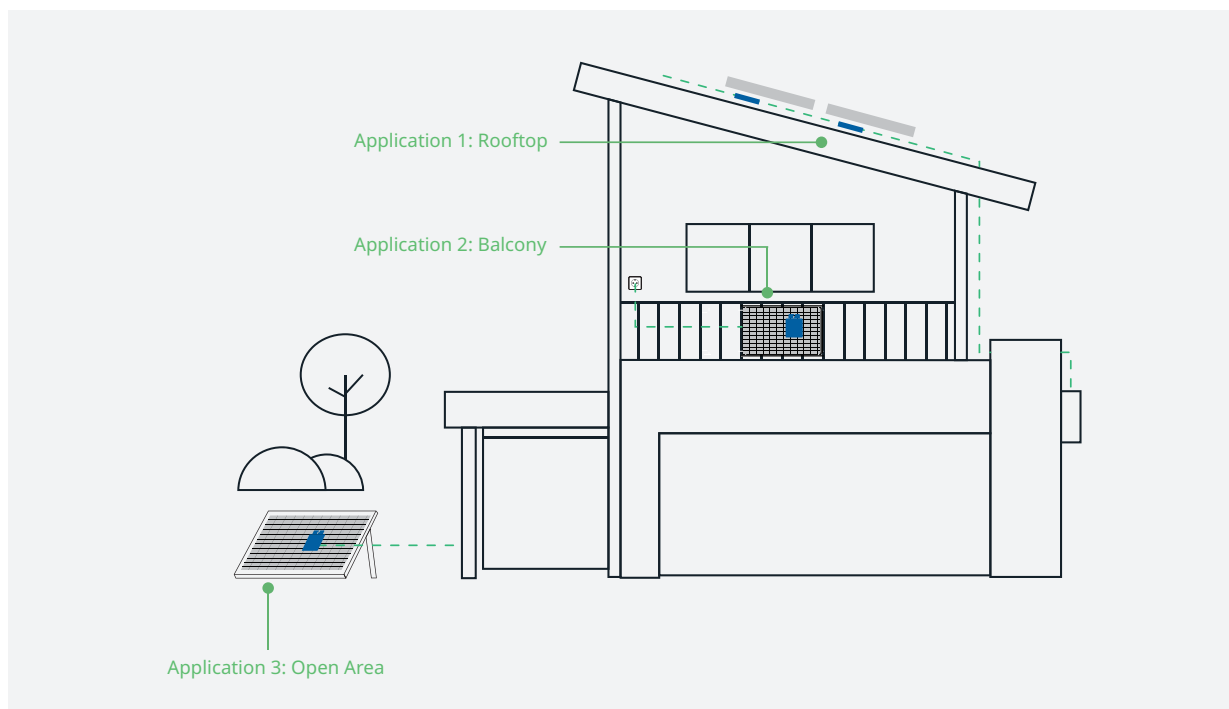

Figure 1-1 HMS-500W-1T Microinverter System Application

NOTE

For each type of setup, you'll need different accessories.





- **Single-Microinverter system:**

You can order an HMS Plug and Play Cable to connect the microinverter to the socket. Or, you can order an HMS Field Connector and get an AC cable ready for connection.

	<p>HMS Plug and Play Cable</p> <p>It consists of the HMS field connector, AC cable, and a Schuko plug. The HMS field connector is connected to the microinverter, and the Schuko plug is connected to the household socket.</p>		<p>HMS Field Connector</p> <p>It provides a quick and simple electrical connection between the microinverter and the grid by serving as a joining component. To use it, you should prepare an AC cable to connect to it to form the AC end cable.</p>
---	--	---	--

- **Multi-Microinverter system:**

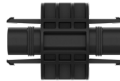
You'll need to order the HMS Cable System and prepare an AC cable and a distribution box to connect the microinverters to the grid. The HMS Cable System includes these components:

	<p>HMS Connection Cable</p> <p>Make a customized AC Trunk by using the HMS Trunk Connectors and HMS Extension Connectors.</p>		<p>HMS Trunk Connector</p> <p>Used to connect the microinverter's AC output to the AC Trunk, as well as to join together multiple HMS Connection Cables to create the AC Trunk.</p>
	<p>HMS Cable Terminal Connector</p> <p>Used to form the AC cable into an AC End Cable, which completes the connection between the end of the AC Trunk and the distribution box.</p>		<p>HMS Extension Connector</p> <p>Used to extend your cable runs when the distance between two microinverters exceeds the standard length of an HMS Connection Cable.</p>
	<p>HMS Sealing Cap</p> <p>Used to cover the unused connection port on the HMS Trunk Connector, which is typically located at the beginning of the AC Trunk.</p>		<p>HMS Disconnect Tool</p> <p>A versatile tool that can be used to take apart connectors, tighten nuts, and loosen nuts.</p>

How the Hoymiles Microinverter System Works

In a typical microinverter system, a few parts team up to turn sunlight into power you can use.

- **PV modules**

The PV modules capture sunlight and change it into DC electricity.

- **Microinverters**

Microinverters are small inverters installed directly on PV modules or nearby. They convert DC electricity from the PV modules into AC electricity, which can power homes or be fed back into the grid. Microinverters use a sophisticated MPPT algorithm to optimize the performance of each PV module. This ensures that even if one PV module under performs, it will not drag down the overall performance of the other PV modules in the row.

- **S-Miles Cloud**

The S-Miles Cloud is a comprehensive monitoring and analysis platform. It watches over the microinverter system from afar, providing real-time insights into the whole system's performance and enabling you to keep track of your microinverter system's status. The S-Miles Cloud also enables remote monitoring, module-level monitoring, as well as efficient operations and maintenance (O&M).

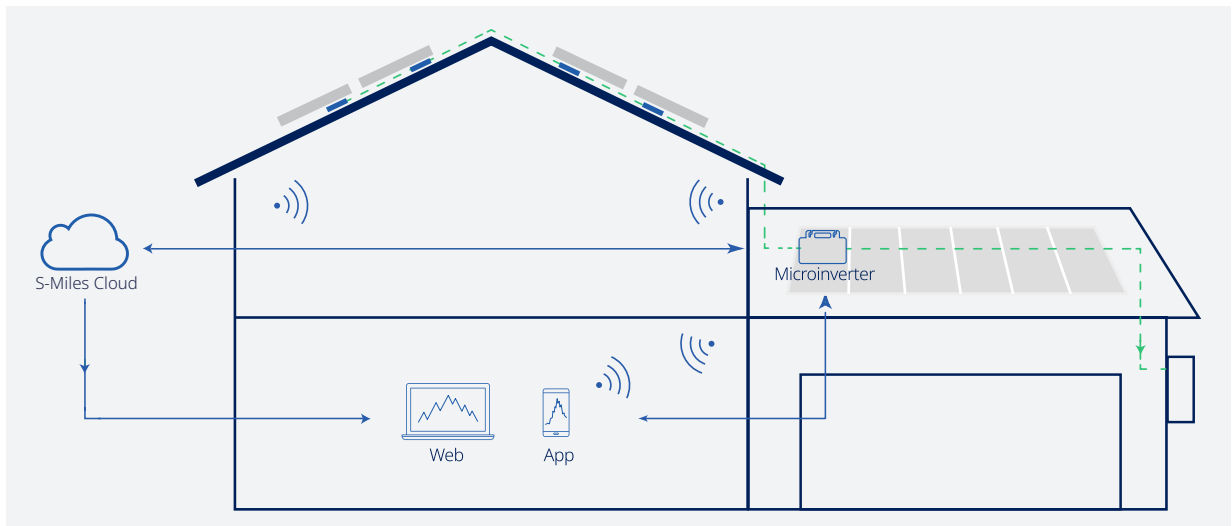

Figure 1-2 HMS-500W-1T Microinverter System Diagram

What's New about the HMS-500W-1T Series Microinverters

The new thing about the HMS-500W-1T series microinverters is that it offers two modes to track, manage, and optimize the whole system:

- **Direct connection:**

This mode lets you see what's happening with the microinverter without needing to sign up or set up anything online. You can use the S-Miles Installer app to talk to the microinverter directly through the built-in Wi-Fi module. It's handy for checking real-time data and controlling functions of the microinverter locally.

- **Remote connection:**

In this mode, single or multiple microinverters communicate with the S-Miles platform via Wi-Fi. You need to have a Hoymiles account and create an online power plant. You can view the performance of all devices under your plant by connecting the microinverter to the platform via a router.

3.2 Appearance and Dimensions

NOTE

The appearance and dimensions shown here are for reference only. The actual product you receive may differ.

Appearance

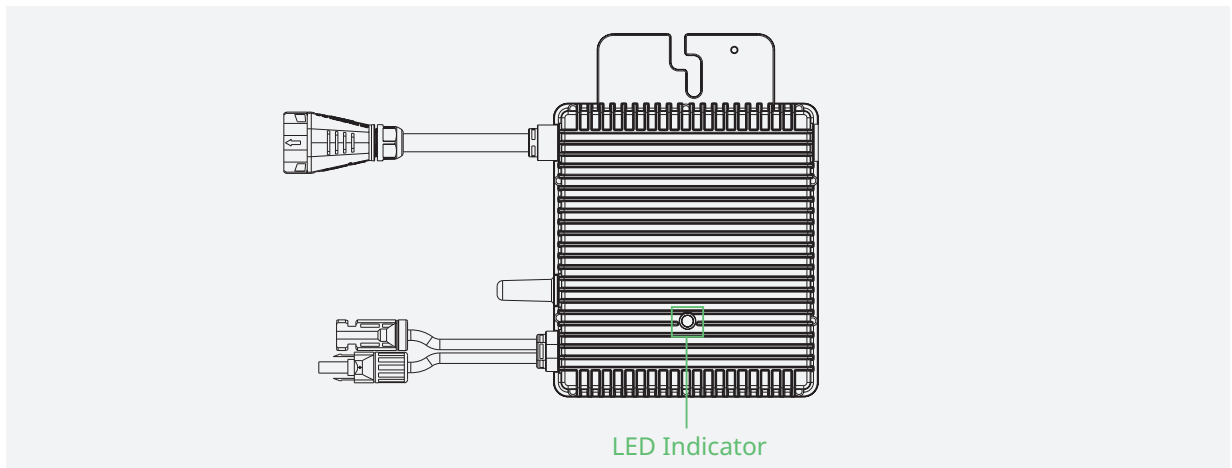
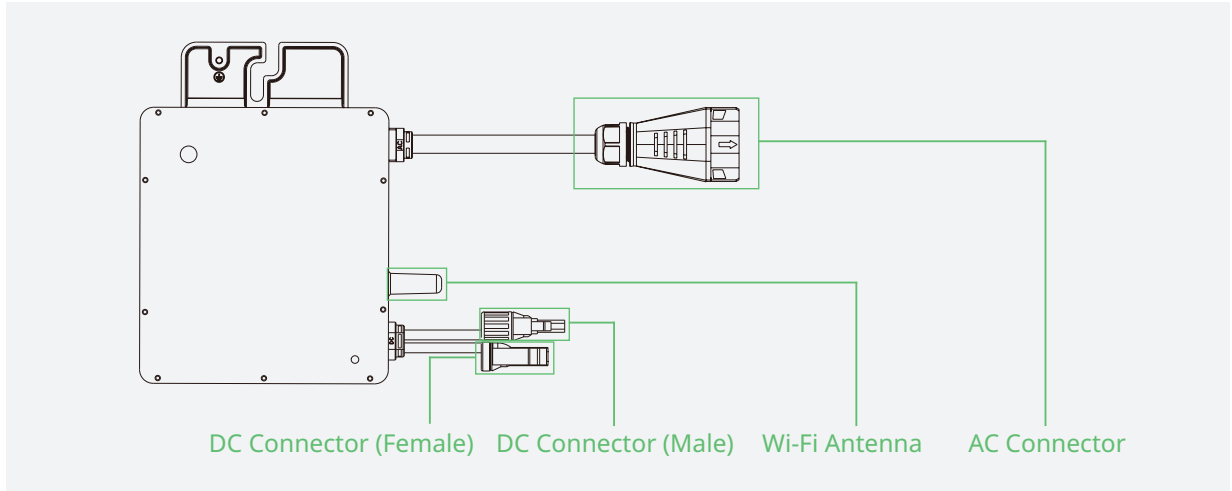

Dimensions (mm)

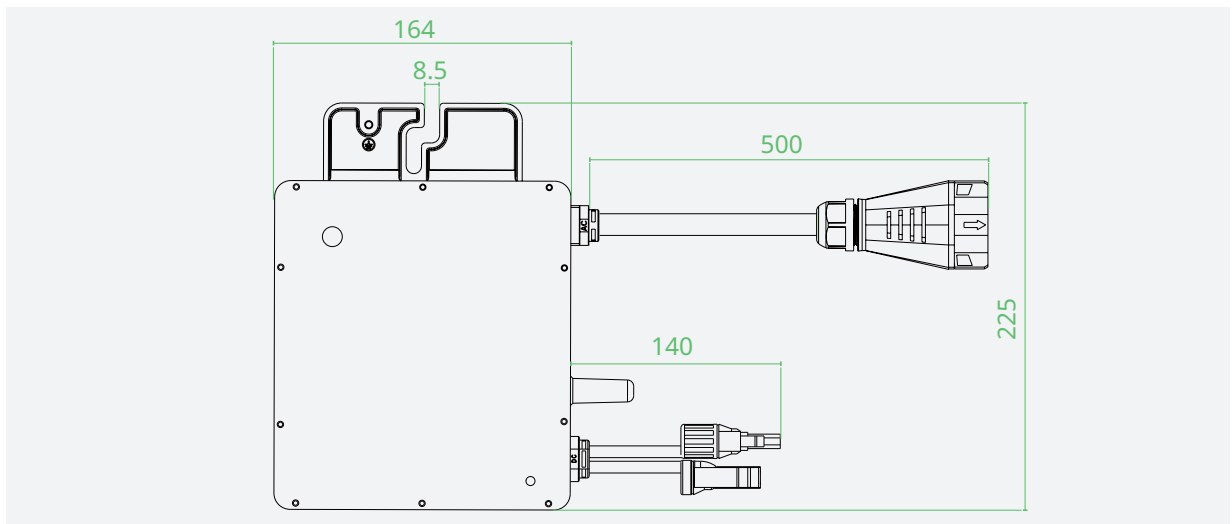

4 Installation Steps

4.1 Preparation

Unpacking the Box

The microinverter has been thoroughly tested and was subject to a strict inspection before delivery. However, damage may still occur during shipping.

Conduct a detailed inspection after unpacking the microinverter:

- Check for any external damage
- Check and confirm that all items have been included

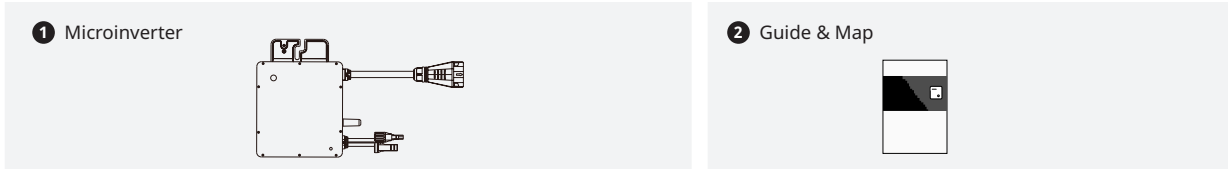

NOTICE
Immediately contact your supplier or distributor upon noticing any damaged or missing parts.

Checking the Parts

• Single-Microinverter System

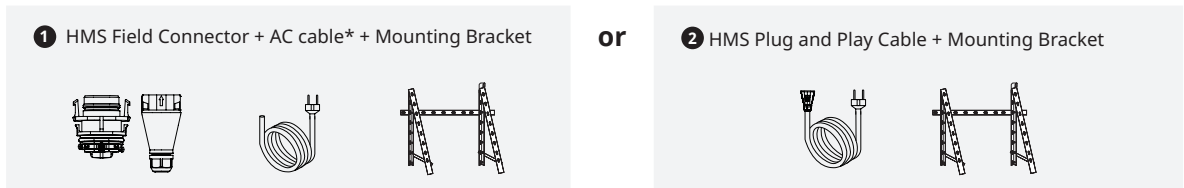

• Multi-Microinverter System

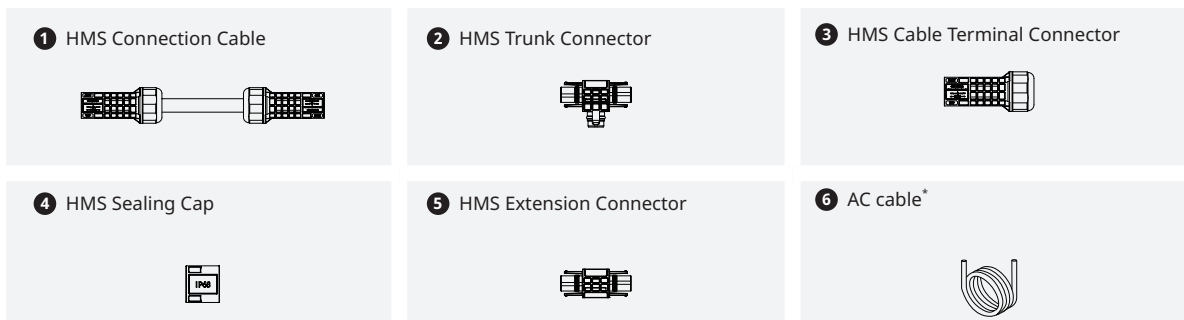

NOTE

Hoymiles doesn't offer the AC cable and mounting bracket for sale. You need to buy them separately. When purchasing them, ensure compliance with local regulations and consider the following guidelines:

- **AC cable:** Ensure it meets the necessary requirements.

Type	Wire Type	Size	Cross-section Diameter	Maximum Voltage
Single-Microinverter System	Outdoor Use, Copper Wire, Schuko Plug*	1.5/1.0 mm ²	8 to 9.5 mm	-
Multi-Microinverter System	Outdoor Use, Copper Wire	2.5/4/6 mm ²	≤16.5 mm	600 V













* The SCHUKO plug is widely used in Europe for connecting microinverters to the socket. However, you still have the option to choose a plug that meets the local grid regulations for connecting your microinverter system to the grid.

- **Mounting Bracket:** Ensure the bracket has the load-bearing capacity and wind resistance to support the microinverter effectively.





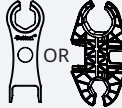

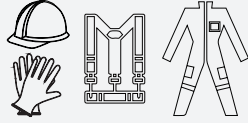



Checking the Tools

Installation tools include but are not limited to the following recommended ones. If necessary, use other auxiliary tools on site.

• Single-Microinverter System

1 Marker 	2 Phillips Screwdriver 	3 Cable Cutter 	4 Wire Stripper 	5 Crimping Tool  (1.5 mm ²)	6 Torque Wrench  (1.5-3 N•m)
7 Crimp Ferrules  (1.5 mm ²)	8 Cable Ties  (2-9 N•m)	9 Electric Screwdriver 	10 M8 Screws 	11 Disconnect Tool  OR 	12 PPE 

• Multi-Microinverter System

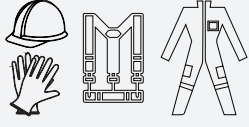
1 Marker 	2 Steel Tape 	3 Cable Cutter 	4 Wire Stripper 	5 Crimping Tool  (2.5/4/6 mm ²)	6 Torque Wrench  (1.5-3 N•m)
7 Electric Screwdriver  (2-9 N•m)	8 M8 Screws 	9 Cable Ties 	10 Disconnect Tool 	11 PPE 	

Downloading the Application

Download the S-Miles Installer application. To download,

- Scan the QR code on the right, or,
- Search for “S-Miles Installer” on the App Store or Google Play Store



S-Miles Installer | Q

Planning the Microinverters

You should specify the number of microinverters per AC output line based on the AC cables’ capacity.

Maximum Microinverter Number per Line					
Model	HMS-300W-1T	HMS-350W-1T	HMS-400W-1T	HMS-450W-1T	HMS-500W-1T
2.5 mm ²	18@220 V 19@230 V 20@240 V	15@220 V 16@230 V 17@240 V	13@220 V 14@230 V 15@240 V	12@220 V 12@230 V 13@240 V	11@220 V 11@230 V 12@240 V

4 mm ²	24@220 V 26@230 V 27@240 V	21@220 V 22@230 V 23@240 V	18@220 V 19@230 V 20@240 V	16@220 V 17@230 V 18@240 V	14@220 V 15@230 V 16@240 V
-------------------	----------------------------------	----------------------------------	----------------------------------	----------------------------------	----------------------------------

NOTICE

- Limits are determined based on AC cable ampacity, which can vary. Check local codes to determine the exact restrictions.
- Multiple 1-in-1, 2-in-1, and 4-in-1 microinverters can be connected to the same AC output line, as long as the total current doesn't exceed the local regulations' ampacity limits.

Determining the Installation Position

Consider the following to ensure the optimal location for the microinverter:

IP 67

- The microinverter meets the IP67 rating for environmental protection and can be installed indoors or outdoors.



- Shield the microinverter and DC connections from sunlight, rain, snow, UV, and other elements by installing them beneath the PV module.
- Install the microinverter beneath the PV modules to prevent power derating caused by temperature rise.



- Provide a minimum clearance of 2 cm around the microinverter enclosure to ensure proper ventilation and heat dissipation.



- Align environmental conditions with microinverter requirements specified in the "[Technical Data](#)" section, including the protection level, temperature, humidity, altitude, and more.



- Do not install the microinverter in:
 - ▷ Areas near corrosive, flammable, or explosive materials.
 - ▷ Areas accessible to children or pets.



- To avoid communication interference, steer clear of metal obstacles or large obstructions near the installation site of the microinverter.

4.2 Single-Microinverter System

Refer to the following steps to install the microinverter.

You can visit our [YouTube channel](#) or scan the QR code to watch the tutorial videos.



⚠️ DANGER!

- Make sure there is no electrical connection before proceeding with the installation.
- During installation, secure the whole microinverter system to prevent it from falling.

⚠️ WARNING!

Check the balcony railing for stability, weight capacity, and a smooth, level surface for bracket attachment.

⚠️ CAUTION!

Given the complexity of balcony installations, ensure that your installation adheres to the required environmental and safety standards. Seek professional advice if necessary.

NOTICE

Due to the on-site conditions of the balcony and the placement of the microinverter, you may need additional DC Extension Cables. You can purchase them from Hoymiles by emailing sales@hoymiles.com.

Assembly Diagram

Hoymiles offers two options for building a single-microinverter system:

• **Plug-and-Play Configuration:**

In this setup, you should order an HMS Plug and Play Cable from Hoymiles. One end of the HMS Plug and Play Cable directly connects to the microinverter, while the other end plugs into the socket. This configuration ensures simple and convenient installation without requiring additional stripping and crimping operation.

• **Field-Connected Plug Configuration:**

In this setup, you should order an HMS Field Connector from Hoymiles and prepare an AC cable with a Schuko Plug (refer to "[Checking the Tools](#)" for AC cable requirements). Connect one end of the AC cable to the HMS Field Connector, then attach the HMS Field Connector to the microinverter. Finally, plug the other end of the AC cable with the Schuko plug into the socket.

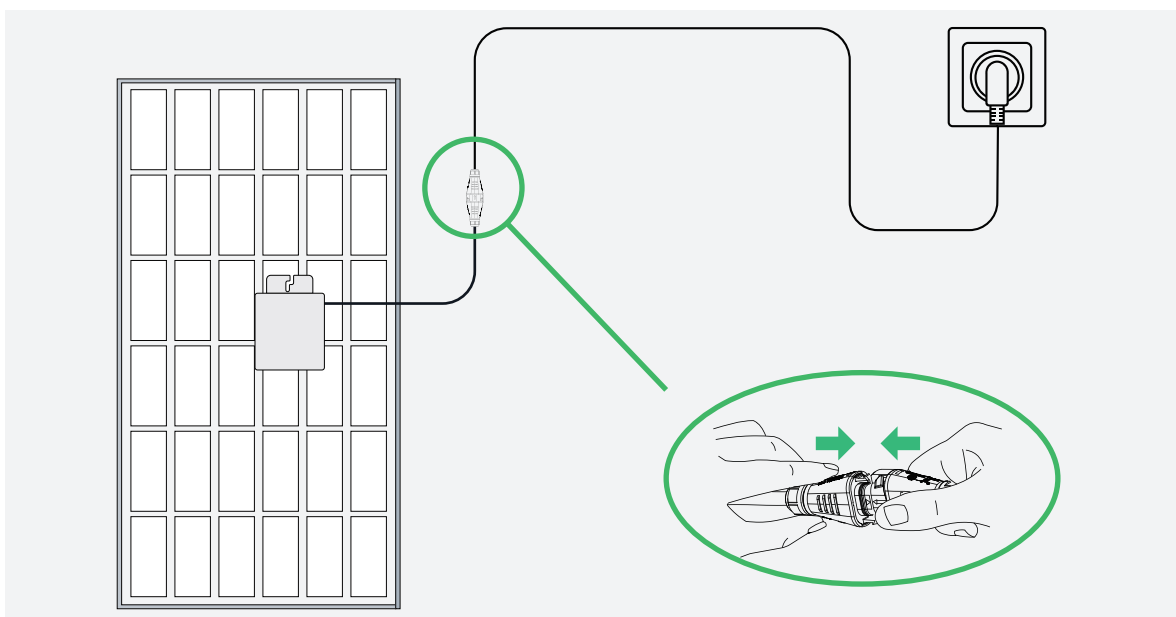

Procedure

Plug-and-Play configuration and the field-connected plug configuration are the same until Step 4. Then, in Step 5, you can choose to order the HMS Field Connector or the HMS Plug and Play Cable. If you are not sure which way is better, you can ask our [Technical Support Team](#) for help.

Step 1 Attach the Microinverter

- Follow the manufacturer's instructions to assemble the bracket.
- Attach the microinverter (label side facing the PV module) to the bracket, ensuring the microinverter is properly aligned.
- Secure the microinverter to the bracket with M8 screws (Torque: 9 N•m). Do not over-torque.

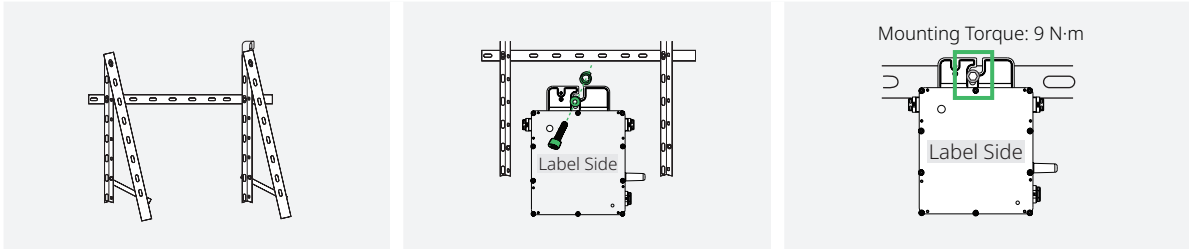

⚠ WARNING!

- The AC cables already include earth wires for direct grounding. If external grounding is required at your installation site, you can order the grounding accessory by emailing sales@hoymiles.com.
- Allow at least 2 cm of space around the microinverter for ventilation and heat dissipation.



Step 2 Complete the Installation Map

- Peel off the microinverter's removable SN label.
- Affix the label to the respective location on the installation map.

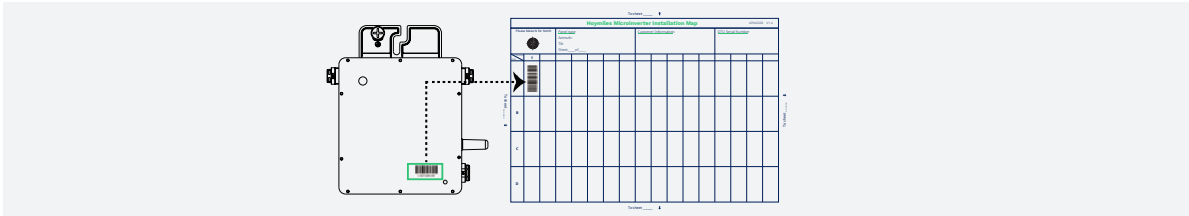

Step 3 Connect the PV Modules

- Connect the female connectors of PV modules to the DC male connectors of the microinverter.
- Connect the male connectors of PV modules to the DC female connectors of the microinverter.
- Mount the PV modules above the microinverters.

⚠ CAUTION!

Please note that the microinverter's DC male connector is marked with a "+" sign, while the DC female connector is marked with a "-" sign. These symbols simply indicate the gender of the connector and do not imply the positive or negative current.

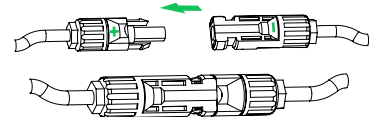

Step 4 Attach the Bracket

- Follow the manufacturer's instructions to securely attach the bracket to the balcony railing.
- Verify the bracket is aligned correctly, level, and stable.

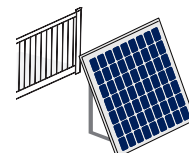

Step 5 Power on the Microinverter System

• Use HMS Plug and Play Cable

- A) Connect one end of the HMS Plug and Play Cable to the microinverter, and the other end to the socket.
- B) Wait five minutes for the system to start producing power.
- C) Check the LED indicator on the connector side of the microinverter. If the microinverter is operating as expected, the LED indicator will flash green. If the LED indicator remains off or lights solid red, see ["6.2 LED Indicator Status"](#).

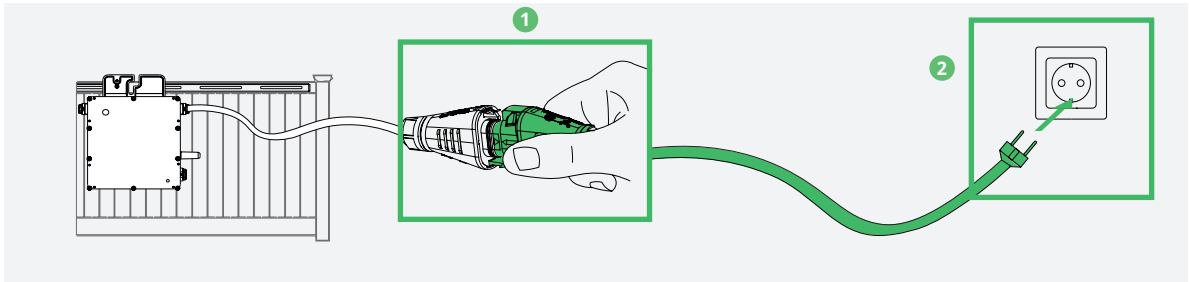

• Use HMS Field Connector

- A) Separate the HMS Field Connector into five parts and slide them over an AC cable.

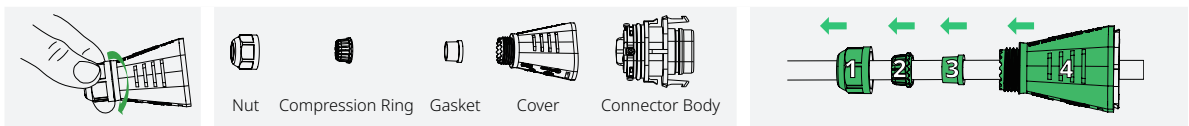

- B) Strip off 25±3 mm of the outer jacket with a diagonal cutter. Then use a wire stripper to strip the insulation to expose 6±1 mm of the conductor.

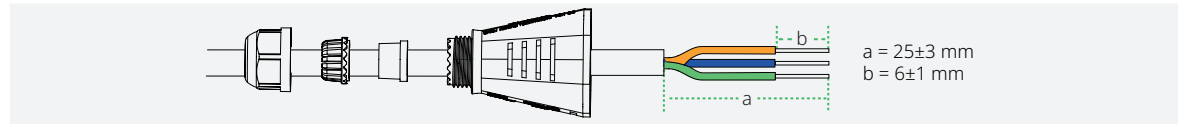

- C) Push the stripped wire end into the crimp ferrules and crimp the ferrule tightly.

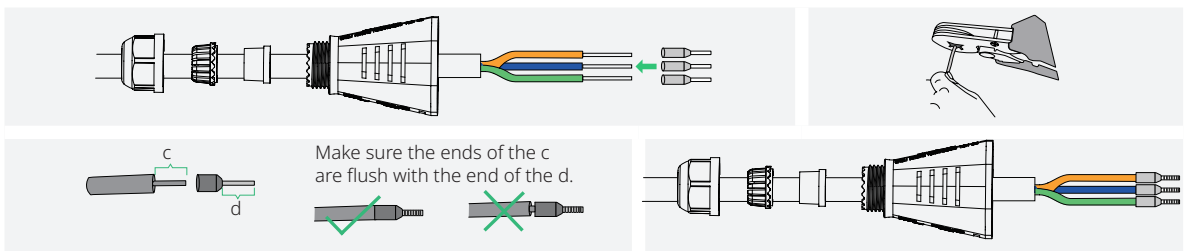

- D) Insert the crimped cable into the connector body. (Wiring color codes may vary. Always adhere to national and site-specific regulations for wiring.)

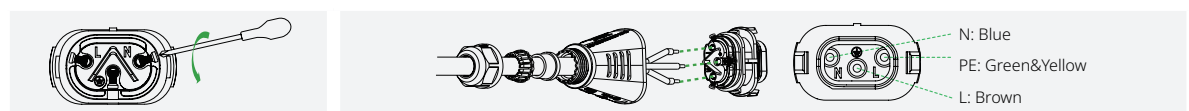

- E) Slide the cover, gasket, compression ring, and nut over the cable, then firmly tighten the nut with a torque wrench (Torque: 2±0.5 N·m).

- F) Connect the HMS Field Connector to the microinverter's output connector until it clicks into place.

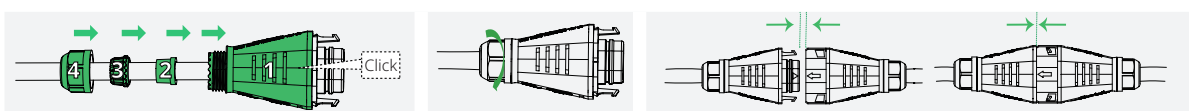

- G) Connect the other end of the AC cable into the socket.
- H) Wait five minutes for the system to start producing power.
- I) Check the LED indicator on the connector side of the microinverter. If the microinverter is operating as expected, the LED indicator will flash green. If the LED indicator remains off or lights solid red, see "[6.2 LED Indicator Status](#)".

4.3 Multi-Microinverter System

Refer to the following steps to install the microinverter.

You can visit our [YouTube channel](#) or scan the QR code to watch the tutorial videos.



⚠ DANGER!

- Disconnect AC circuit breakers and ensure they are not inadvertently reconnected before making any electrical connections.
- Confirm all cables are not powered before performing cable connections.

⚠ WARNING!

- All electrical connections must adhere to local and national standards.
- Ensure all cables are in good condition, properly insulated, not damaged, securely attached, and of an appropriate size.
- Ensure all microinverters and inter-wiring connections are properly set up before installing the PV modules.

⚠ CAUTION!

- Do not pull or hold the AC cable with your hand. Hold the handle instead.
- Securely mount the microinverters using the correct amount of torque. The mounting torque of the M8 screw is 9 N·m. Do not over-torque.

NOTICE

Due to the on-site conditions of the roof and the placement of the microinverter, you may need additional DC Extension Cables. You can purchase them from Hoymiles by emailing sales@hoymiles.com.

Assembly Diagram

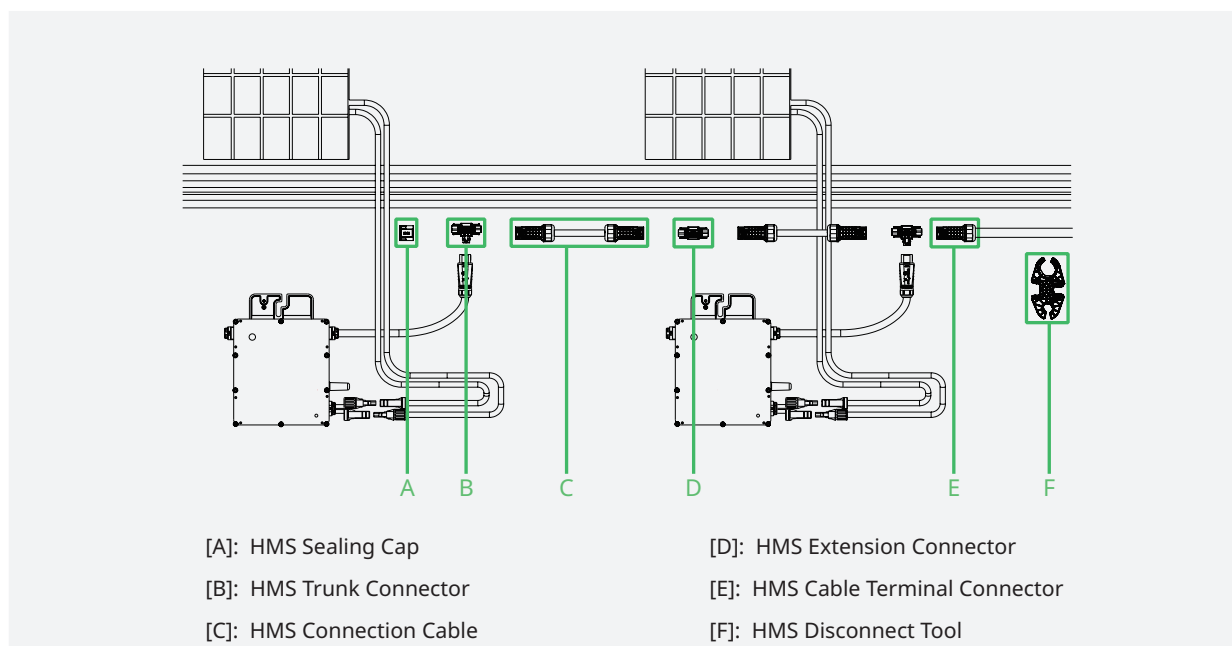

Procedure

Step 1 Attach the Microinverters to the Racking

- A) Plan and mark the position of each microinverter on the racking.
- B) Place the microinverter (label side facing the PV module) onto the racking.
- C) Secure the microinverter to the racking (Torque: 9 N•m).

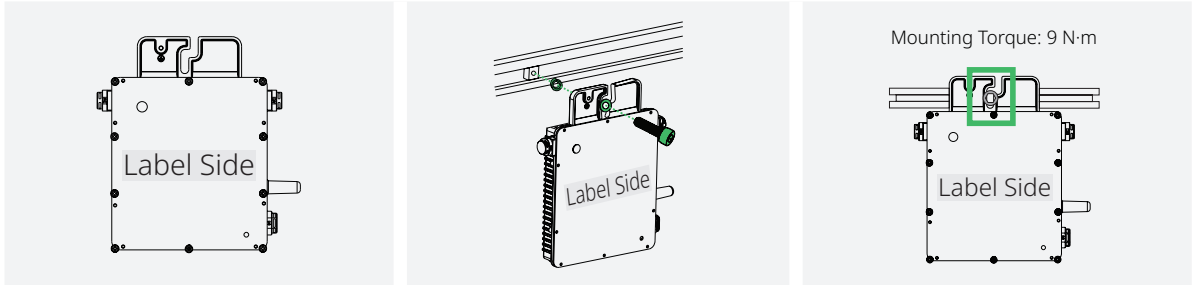

⚠ WARNING!

- Keep a distance between the microinverter and the roof for the best communication quality. If this isn't possible due to site constraints, maximize the separation as much as you can.
- Allow at least 2 cm of space around the microinverter for ventilation and heat dissipation.
- The AC cables already include earth wires for direct grounding. If external grounding is required at your installation site, you can order the grounding accessory by emailing sales@hoymiles.com.



Step 2 Connect the AC Trunk Connector

- A) Connect the HMS Trunk Connector to the microinverter.
- B) Cover the unused port on the HMS Trunk Connector (located at the beginning of the AC Trunk) with an HMS Sealing Cap. Listen for a click as the sealing cap engages.

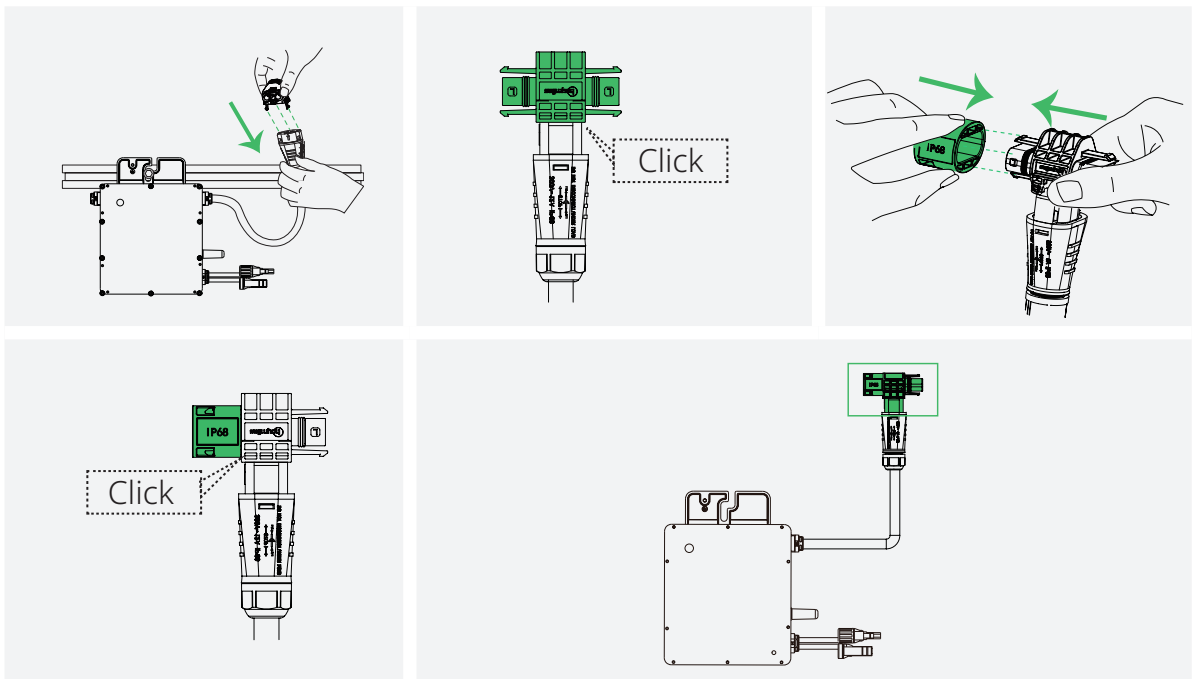
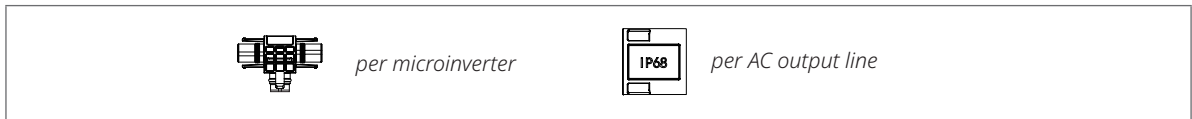

Step 3 Connect Adjacent Microinverters

Use the HMS Connection Cables to connect all microinverters on the AC Trunk one by one. Listen for a click as they engage.

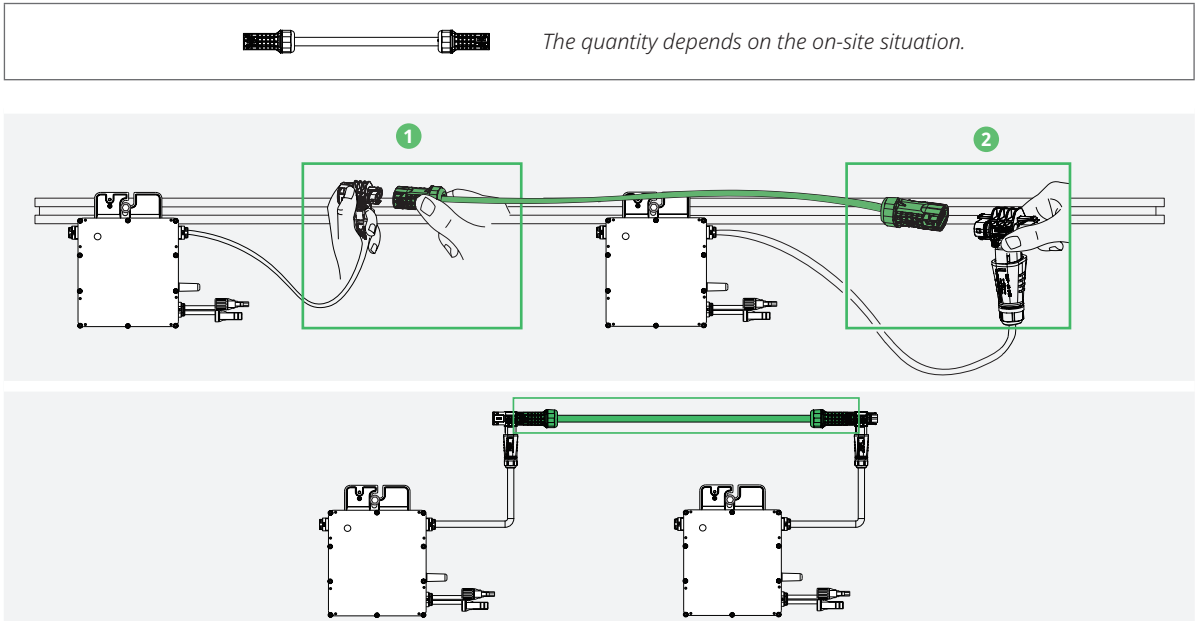

Obstacle Scenario

If you need to space microinverters farther apart due to an obstacle, Hoymiles offers two solutions:

- **Using a longer HMS Connection Cable:** Hoymiles offers cable lengths of 1.1 m, 2.0 m, 2.3 m, 3.0 m, and 4.6 m. If you require a different length, contact our sales team by emailing sales@hoymiles.com.
- **Using an HMS Extension Connector** to connect two HMS Connection Cables into a longer one.

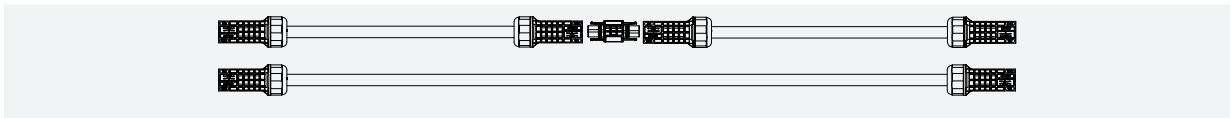

* To disconnect the HMS Extension Connector from the AC Trunk, you must use an HMS Disconnect Tool. (See "7.1 Removing the Microinverter".)

Step 4 Make the AC End Cable

A) Separate the HMS Cable Terminal Connector into six parts, then slide the nut, compression ring, and gasket over the AC cable in the correct order.

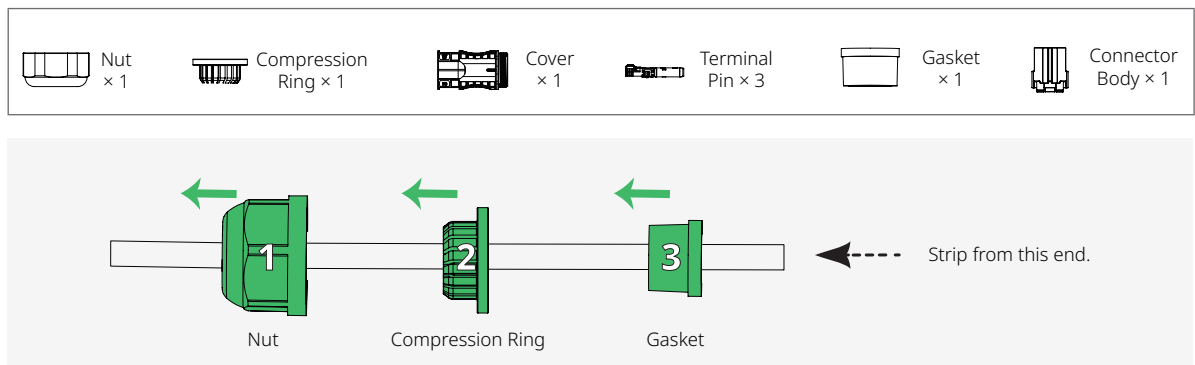

NOTICE

Two terminal pin sizes are available: one for 2.5 mm² cables and the other for 4 mm² or 6 mm² cables. Choose the correct terminal pin size matching the cable size to ensure a reliable and secure connection. Using the wrong size may result in potential issues or connection failures.

- B) Strip off 40±5 mm of the outer jacket with a diagonal cutter. Then use a wire stripper to strip the insulation to expose 6 mm to 7 mm of the conductor.

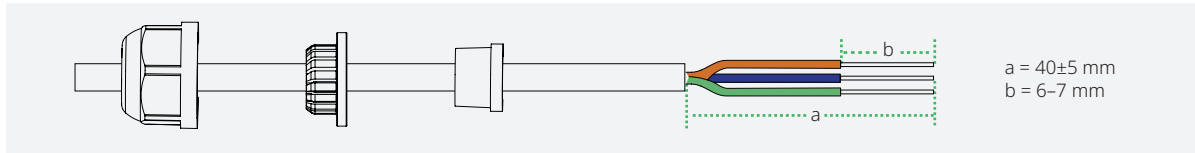
**NOTE**

Take care not to cut individual conductor strands.

- C) Insert the conductors into the terminal pins and crimp the connection with a crimping tool.

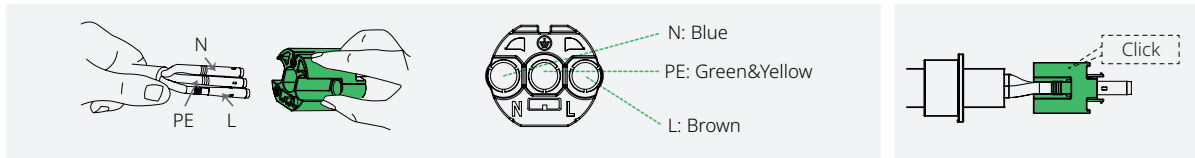

- D) Insert the crimped cable into the connector body.

**NOTICE**

Wiring color codes may vary. Always adhere to national and site-specific regulations for wiring.

- E) Insert the connector body into the cover.

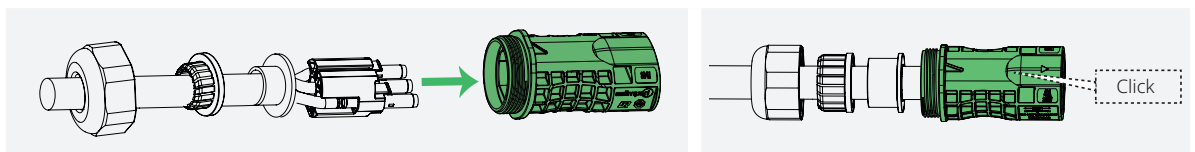

- F) Slide the gasket, compression ring, and nut over the cable assembly. Tighten the nut to 2.5 ± 0.5 N·m.

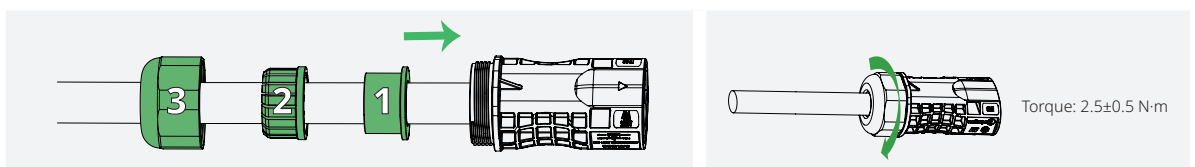

Step 5 Connect the AC End Cable

Connect the AC End Cable to the last HMS Trunk Connector in the AC Trunk. Listen for a click as they engage.

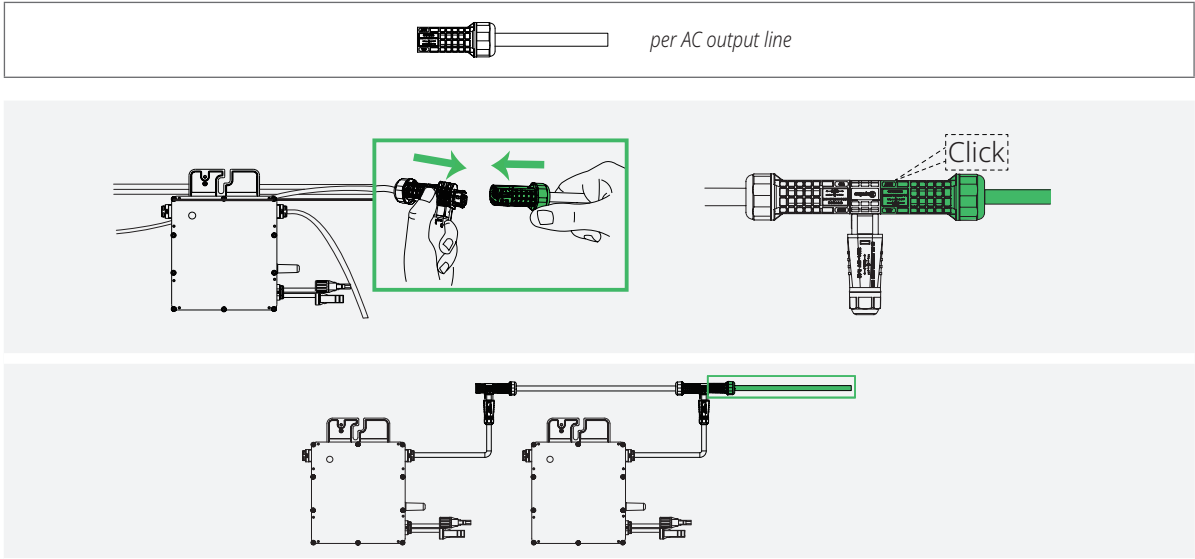

Step 6 Manage the AC Trunk

Secure all cables and connectors to the racking with metal cable ties, following local wiring codes for tie spacing.

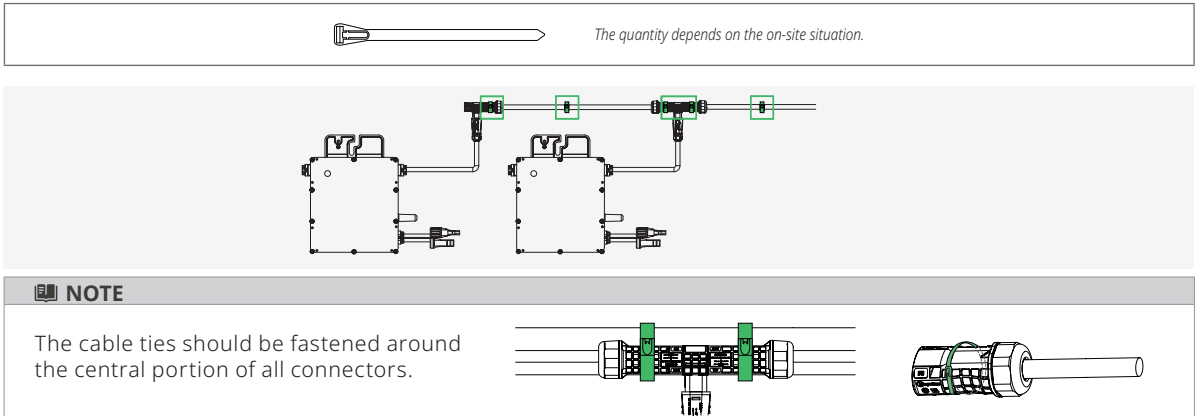

Step 7 Connect to the distribution box

Connect the other end of the AC End Cable to the distribution box.

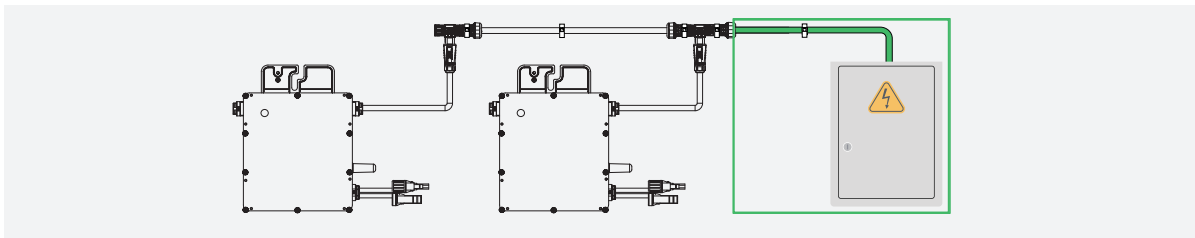

⚠ WARNING!

Please adhere to local wiring codes for wiring safety.

L	N	PE
Brown	Blue	Green&Yellow

Step 8 Complete the Installation Map

- A) Peel off the microinverter’s removable SN label.
- B) Affix the label to the respective location on the installation map.

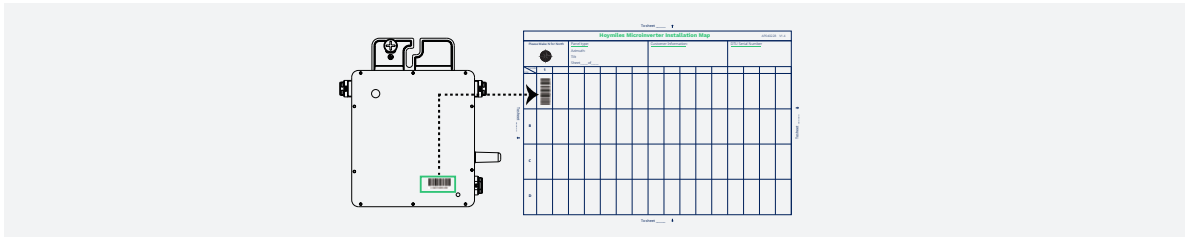

Step 9 Connect the PV Modules

- A) Connect the female connectors of PV modules to the DC male connectors of the microinverter.
- B) Connect the male connectors of PV modules to the DC female connectors of the microinverter.
- C) Mount the PV modules above the microinverters.

⚠ CAUTION!

Please note that the microinverter’s DC male connector is marked with a “+” sign, while the DC female connector is marked with a “-” sign. These symbols simply indicate the gender of the connector and do not imply the positive or negative current.

The diagram shows two types of DC connectors. The top one is a male connector with a green '+' sign, and the bottom one is a female connector with a black '-' sign. A green arrow points from the male connector towards the female connector, indicating they are designed to mate.

Step 10 Start-up

- A) Check the following before powering on the system:

Check Item	Acceptance Criteria
Microinverter	The microinverters are installed correctly and securely.
Cables routing	Cables are routed properly as required.
Cable ties	Cable ties are evenly distributed and no burr exists.
Cable connection	The AC output power cable and DC input power cable are connected correctly, securely, and reliably.

- B) Power on the Microinverter System.
- C) Turn the AC disconnect or circuit breaker for each AC output line **ON**.
- D) Turn the main utility-grid AC circuit breaker **ON**.
- E) Allow five minutes for the system to start generating power.
- F) Check the LED Status. If the microinverter is operating as expected, the LED indicator will flash green. If the LED indicator remains off or lights solid red, see “6.2 LED Indicator Status”.

5 Setting Up and Activating Monitoring

NOTICE

- The network name of the microinverter consists of DTUBI and the last eight numbers of the SN.
- Each microinverter has been initially set with a unique AP password, which is printed on a non-removable label affixed to the right side of the microinverter's silver-colored cover. We recommend you modify the initial AP password upon receiving the microinverter.

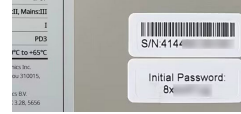

NOTE

- The screenshots provided here are for reference only. The actual screens may vary.
- Refer to the [S-Miles Installer App Operating Guide](#) for additional details on power system implementation.

This section will guide you through connecting to the S-Miles Cloud, setting up the power system, adding devices, and configuring your power system.

Hoymiles offers two methods for viewing data and monitoring the operation of microinverters:

• Direct Connection:

This method is ideal for single-microinverter systems. It allows immediate access to microinverter information and control by connecting to the microinverter's hotspot. This provides convenient and direct control over the microinverter's operation without complex setup processes.

However, please note that you can only track the performance of the microinverter that you've connected directly.

• Remote Connection:

This method is ideal for multi-microinverter systems. To enable remote access, you need to connect the microinverter to the S-Miles Cloud via a router.

Once you log in to your Hoymiles account and create an online power plant, you can monitor the performance of the entire plant from anywhere, at any time.

5.1 Direct Connection

Step 1 Connect to the Microinverter

- Open the S-Miles Installer app and tap **No Account**.
- Scroll down your screen and tap **Enter**.
- Tap the microinverter's hotspot. Then enter the microinverter's AP password.

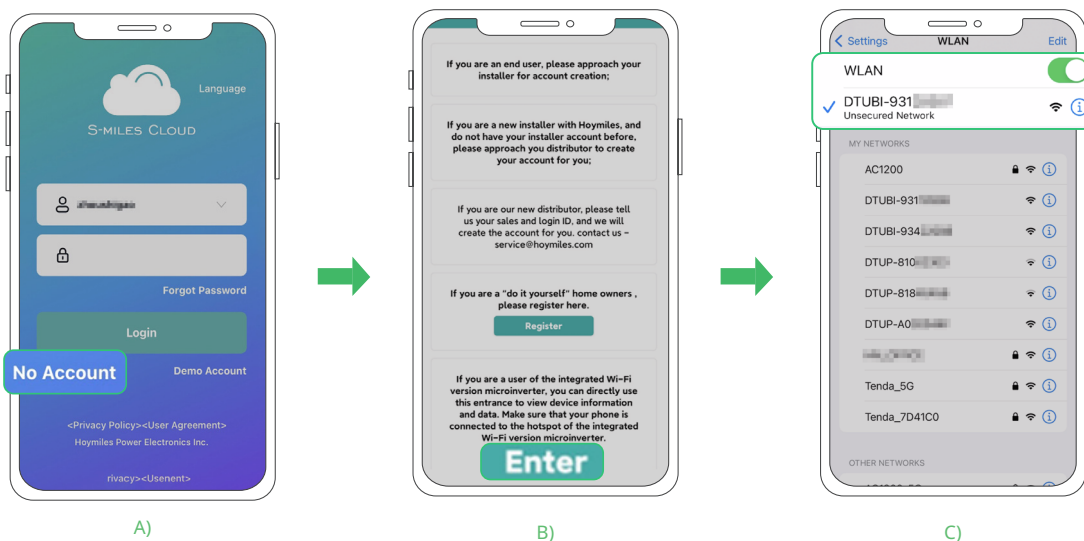

D) Once you successfully connect to the microinverter's hotspot, you will be directed to the **Overview Screen**.



D)

Item	Description
Setting Icon	Navigates to the Device Setting
Daily Energy	Daily power yield
Lifetime Energy	The total amount of energy generated by the plant over its operational lifetime
Total Reduction	The reduction in carbon emissions achieved through solar power generation
Carbon Emission Offset	The green benefits through solar power generation
Power	The line chart illustrates power generation over time.
Production	The bar graph illustrates power generation over time.

Step 2 Set your device

A) On the **Overview Screen**, tap **Setting** .

B) To view the real-time data, tap .

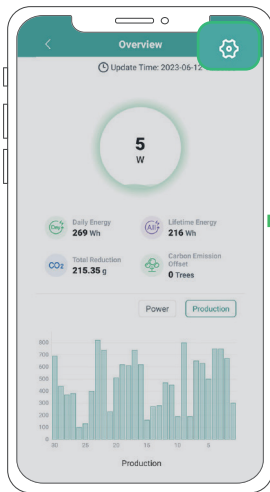

A)-1

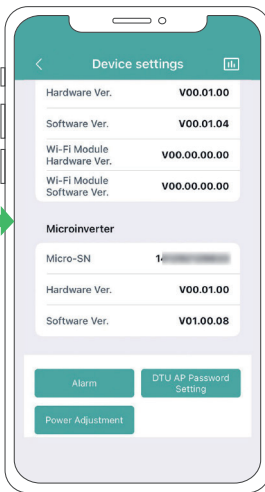

A)-2

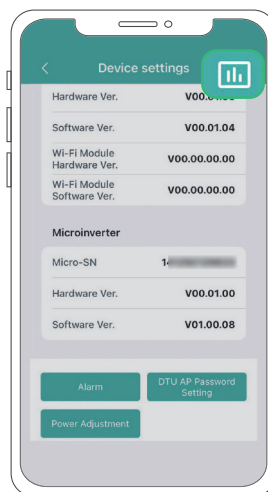

B)-1

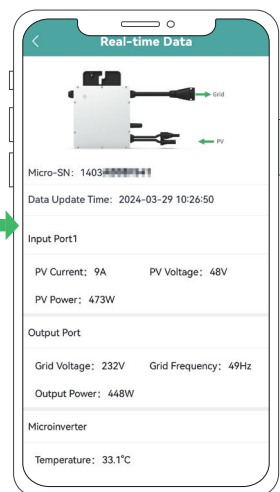

B)-2

C) To view the fault messages, tap **Alarm**.

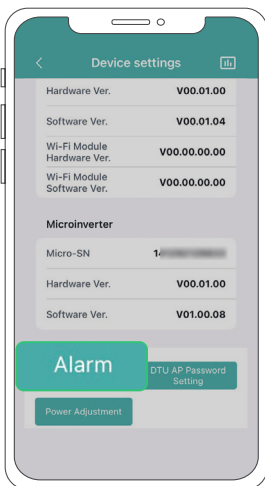

C)-1

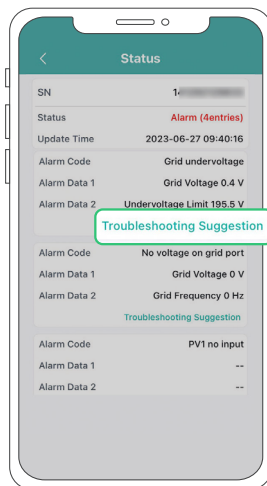

C)-2

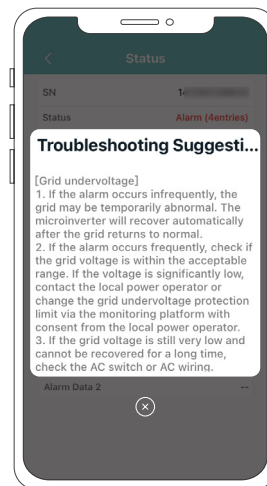

C)-3

- D) To reset the AP Password, tap **DTU AP Password Setting**.
- E) To adjust the active power, tap **Power Adjustment**.

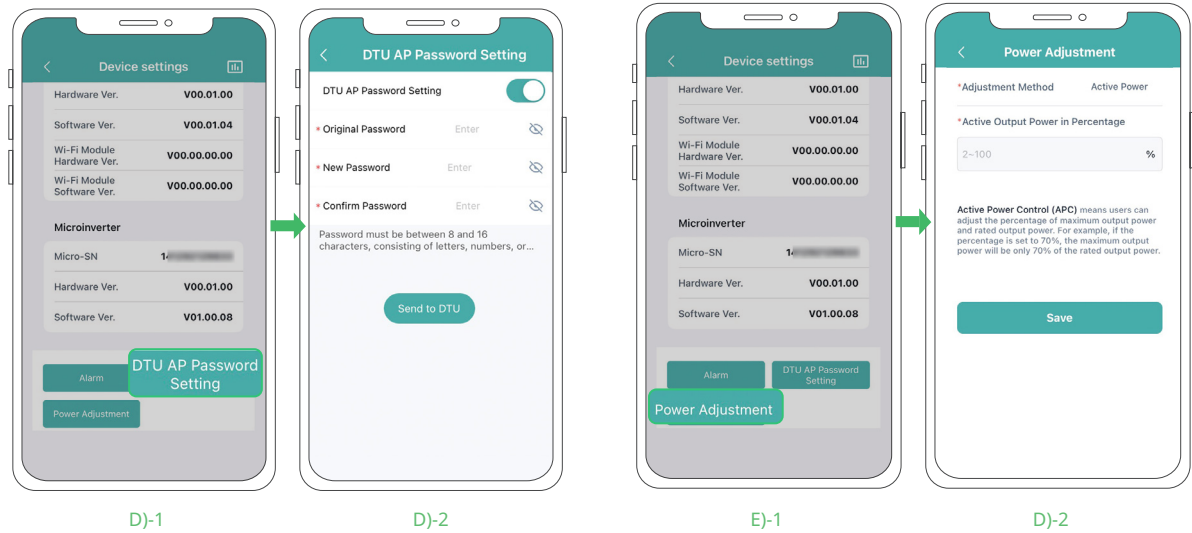

5.2 Remote Connection

Step 1 (Optional) Register a DIY account

- A) Open the S-Miles Installer application, and tap **No Account**.
- B) Scroll down your screen and tap **Register**.
- C) Fill out the registration form with the required information. Then tap **Register**.

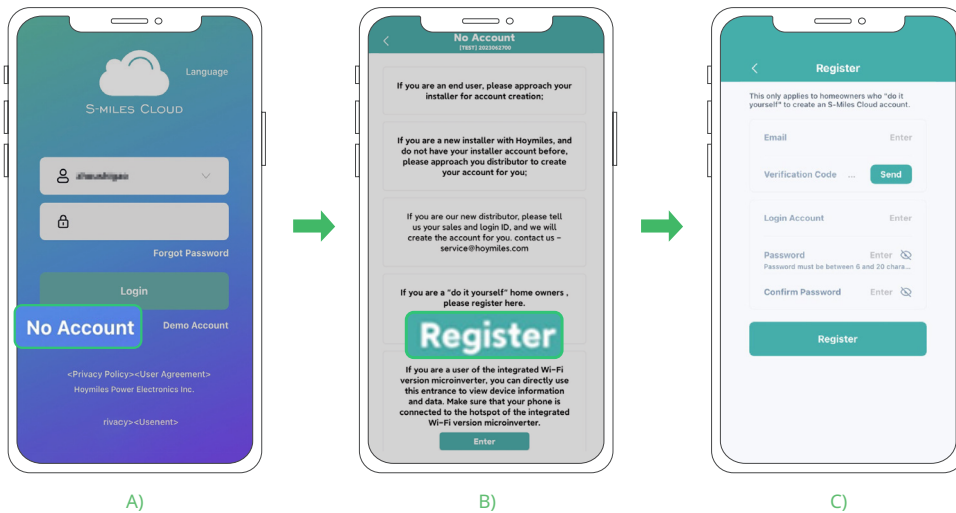

NOTICE

The DIY Account Registration in this manual is currently available exclusively to users in countries or regions of the European Union.

Step 2 Establish an internet connection

- A) Open and log in to the S-Miles Installer application using your credentials.
- B) Tap **O&M** > **Network Config**.
- C) Tap the microinverter's hotspot. Then enter the microinverter's AP password.

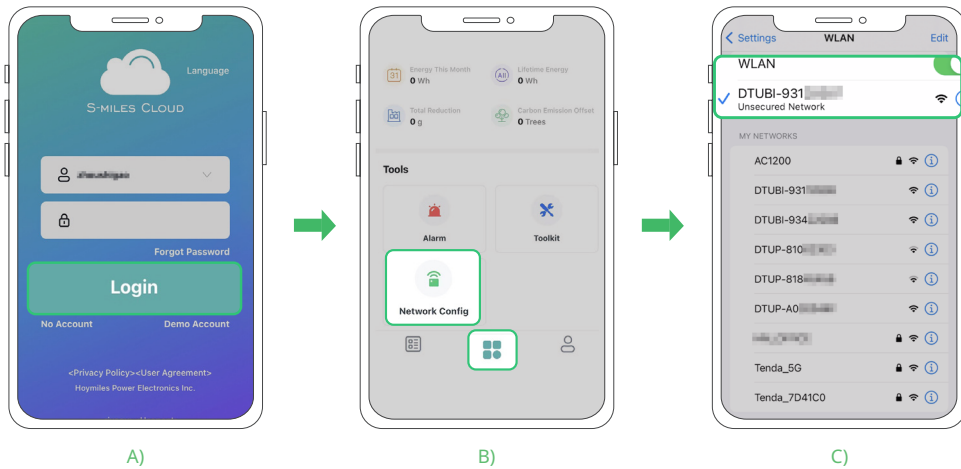

- D) Go back to the app, and tap **O&M** > **Network Config**.
- E) Follow the prompts to configure the network connection.

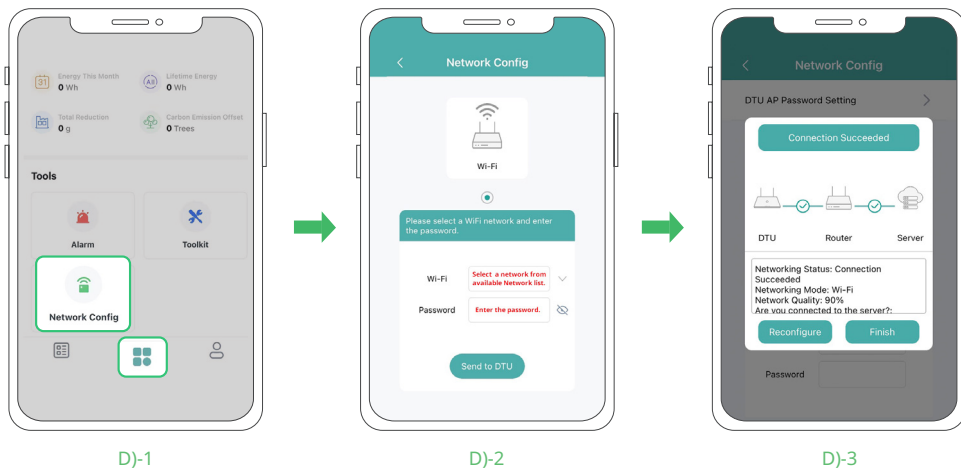

Step 3 Create your power plant

- A) Tap **Plants** > **Add Plant**.
- B) Follow the prompts to fill in the required information. Then tap **Finish** to finalize the plant creation.

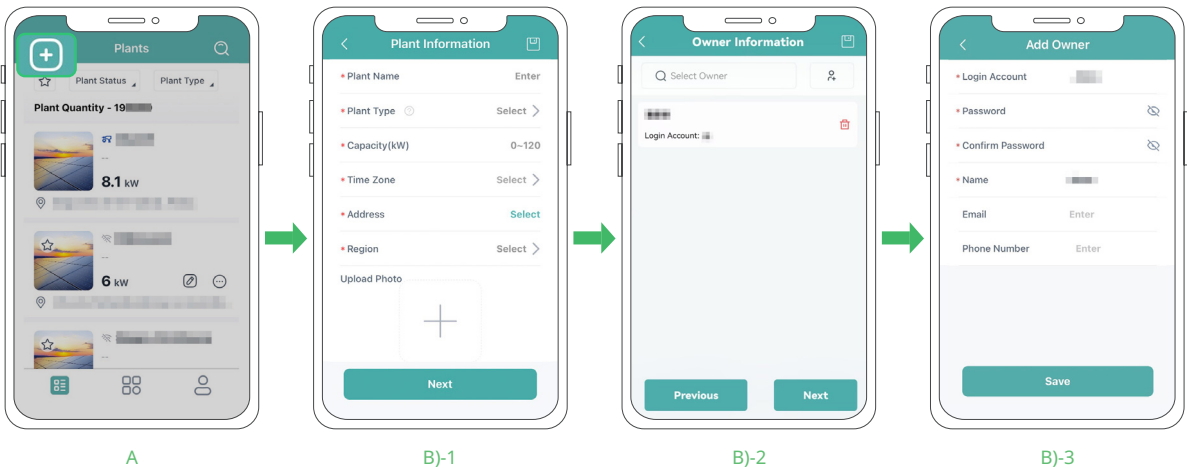

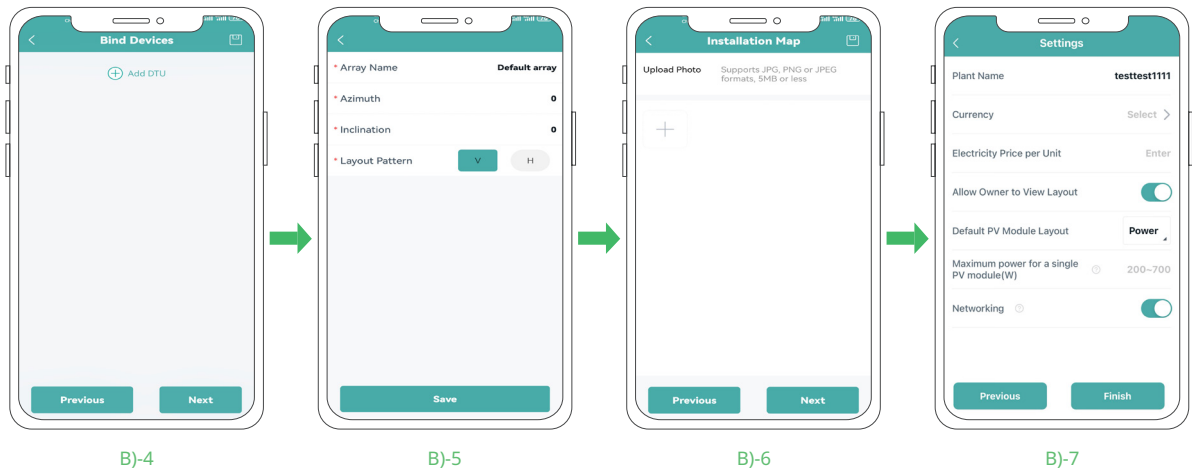

Step 4 Set your power plant

- A) Tap **Plants** > **Search** .
- B) Enter the desired plant name for your search, then tap the plant name to move to the plant homepage.
- C) On the plant homepage, tap **Setting** .



Item	Description
Plant Details	It offers access to geographical location, system capacity, and owner information about the power plant.
Device List	It provides an SN list of devices installed in your power plant.
Power Adjustment	It offers access to adjust the Active Power, Power Factor, and Reactive Power.
Plant Revenue	It provides revenue data over the electricity price, real-time power production data, and historical power production data.

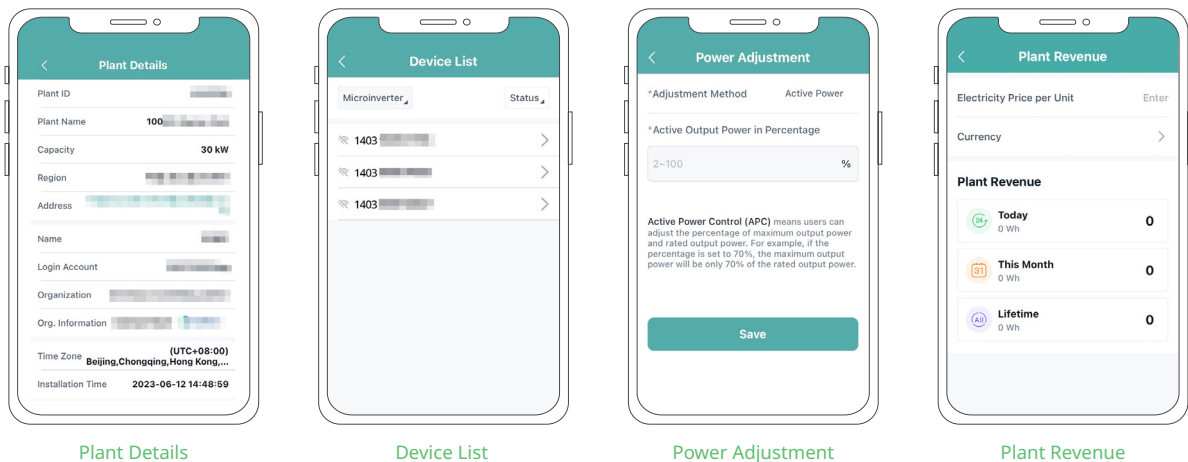

6 Troubleshooting

6.1 Troubleshooting List



Code	Alarm range	Alarm status	Resolutions
121	CU	Over temperature protection	<ol style="list-style-type: none"> 1. Ensure the microinverter installation site is well-ventilated and at a proper ambient temperature. 2. Improve airflow and heat dissipation if necessary. 3. If the airflow are adequate but the alarm still persists, contact your dealer or Hoymiles technical support.
125	CU	Grid configuration parameter error	<ol style="list-style-type: none"> 1. Ensure grid configuration parameters are correct and attempt the upgrade again. For more information about grid profile management, see "S-Miles Cloud Operating Guide (Web)". 2. Please contact your dealer or Hoymiles technical support if the issue persists.
126	-	Software error code 126	<ol style="list-style-type: none"> 1. No further action is necessary if the alarm is accidentally triggered but the microinverter continues to function normally. 2. Please contact your dealer or Hoymiles technical support if the alarm recurs frequently and does not reset.
127	CU	Firmware error	<ol style="list-style-type: none"> 1. Check for the correct firmware and re-attempt the upgrade. 2. Check and ensure the DTU, Hoymiles monitoring system, and microinverter are all connected and communicating with each other. Retry if needed. 3. Please contact your dealer or Hoymiles technical support if the issue persists.
128	CU	Hardware configuration error	<ol style="list-style-type: none"> 1. No special action is required if the alarm is accidental and the microinverter continues to function correctly. 2. Please contact your dealer or Hoymiles technical support if the alarm recurs frequently and does not reset.
129	CU	Abnormal bias	<ol style="list-style-type: none"> 1. No further action is necessary if the alarm is accidentally triggered but the microinverter continues to function normally. 2. Please contact your dealer or Hoymiles technical support if the alarm recurs frequently and does not reset.
130	CU	Offline	<ol style="list-style-type: none"> 1. Please ensure the microinverter is functioning correctly. 2. Check the communication status between the DTU and Hoymiles monitoring system, or between the DTU and microinverter, and make the necessary improvements if the communication appears poor. 3. Please contact your dealer or Hoymiles technical support if the alarm recurs frequently and does not reset.
141	Grid	Grid overvoltage	<ol style="list-style-type: none"> 1. Sudden, accidental activation of the alarm might be the result of a temporary irregularity in grid voltage. The microinverter will recover automatically once the grid voltage stabilizes. 2. Check whether the grid voltage is in the acceptable range in the event of recurring alarm activation. Contact your local power operator or adjust the grid overvoltage protection limit through the Hoymiles monitoring system with consent from the local power operator if the grid voltage is not within acceptable limits.
142	Grid	10 min value grid overvoltage	
143	Grid	Grid undervoltage	
144	Grid	Grid over-frequency	
145	Grid	Grid under-frequency	

146	Grid	Rapid grid frequency change rate	<ol style="list-style-type: none"> 1. Sudden, accidental activation of the alarm might be the result of a temporary irregularity in grid voltage. The microinverter will recover automatically once the grid voltage stabilizes. 2. Check whether grid voltage is in the acceptable range in the event of recurring alarm activation. Contact your local power operator or adjust the grid overvoltage protection limit through the Hoymiles monitoring system with consent from the local power operator if the grid voltage is not within acceptable limits.
147	Grid	Power grid outage	Check whether a power grid outage occurred.
148	Grid	Grid disconnection	Check the condition of the AC switch or AC wiring for issues.
149	Grid	Island detected	<ol style="list-style-type: none"> 1. Sudden, accidental activation of the alarm might be the result of a temporary irregularity in grid voltage. The microinverter will recover automatically once the grid voltage stabilizes. 2. If all the microinverters in your station frequently trigger alarms, reach out to the local power operator to investigate potential grid islands. 3. If the alarms do not stop, please contact your dealer or Hoymiles technical support.
171	-	Abnormal phase-to-phase difference	Confirm that the wiring for each phase is correct. This fault is usually caused by the wrong phase.
209	-	PV-1 no input	<ol style="list-style-type: none"> 1. Confirm that the port is connected to the PV module. 2. If the PV module is indeed connected, examine the DC cable connection between this port and the PV module.
215	-	PV-1 input overvoltage	<ol style="list-style-type: none"> 1. Ensure the PV module's open-circuit voltage is less than or equal to the maximum input voltage. 2. If it is within the normal range, contact your dealer or Hoymiles technical support.
216	-	PV-1 input undervoltage	<ol style="list-style-type: none"> 1. Ensure the PV module's open-circuit voltage is not lower than the minimum input voltage. 2. If it is within the normal range, contact your dealer or Hoymiles technical support.
301 - 311	-	Hardware error code	<ol style="list-style-type: none"> 1. No further action is necessary if the alarm is accidentally triggered but the microinverter continues to function normally. 2. Please contact your dealer or Hoymiles technical support if the alarm recurs frequently and does not reset.





6.2 LED Indicator Status

The LED indicator on the microinverter indicates various statuses. The following table details the possible LED statuses and what they mean.

Start-up

LED	Time Gap		Indication
Flashing green	0.3s, 5 times		Start-up Success
Flashing red	0.3s, 5 times		Start-up Failure, Microinverter Failure
Alternating red and green flashing	1s		Firmware Failure

Operation

LED	Time Gap		Indication
Flashing green	1s		Normal Power Production
Flashing green	2s		The microinverter is generating power, but one or more inputs are registering as abnormal.
Flashing red	0.5s		Control Unit Failure
Flashing red	1s		AC Grid Failure
Solid red	-		Hardware Failure

NOTE

- The microinverter is powered by the DC side. Check the DC side connection if the LED indicator is not illuminated. If the connection and input voltage are normal but the LED indicator is not on, contact your dealer or Hoymiles technical support team for further assistance (see "[Contact us](#)").
- All faults on microinverters are reported to the S-Miles Cloud via the DTU. Refer to the S-Miles Installer/End-user Application or S-Miles Cloud interface for more information.
- Ensure the grid connection is normal.

6.3 AP Password Troubleshooting

If you reset the microinverter's password and later forget it, you can revert to the initial password using the following method.

NOTICE

- This process has a time limit of 20 minutes, and it must be completed within that timeframe.
- For forgotten initial passwords, you can contact [Hoymiles Technical Support](#) for assistance.

• For Single-Microinverter System:

- Ensure the grid connection status is normal.
- Unplug the plug and disconnect the grid voltage for 5 to 10s.
- Plug in the plug and allow the grid voltage to continue for at least 5 to 10s.
- Unplug the plug and disconnect the grid voltage for 5 to 10s.
- Plug in the plug and allow the grid voltage to continue for at least 5s.

• For Multi-Microinverter systems:

- Ensure the grid connection status is normal.
- Disconnect the circuit breaker and grid voltage for 5 to 10s.
- Reconnect the circuit breaker and allow the grid voltage to continue for 5 to 10s.

- D) Repeat the disconnection of the circuit breaker and grid voltage for 5 to 10s.
- E) Reconnect the circuit breaker and allow the grid voltage to continue for at least 5s.

6.4 Wireless Network Troubleshooting

There are two potential indicators of a Wi-Fi connection problem:

- Low signal bars displayed on the microinverter or plant homepage.
- Inability of the S-Miles Cloud platform to display data.

To troubleshoot this problem, please follow the procedure listed below.

Step 1: Restart Microinverter

- A) Restart the microinverter using the S-Miles Cloud platform or the S-Miles Installer application.
- B) If the Wi-Fi signal remains weak, proceed to step 2.

Step 2: Check Router Configuration

- A) Access your router's settings.
- B) Find the Wi-Fi settings.
- C) Change the frequency from 5GHz to 2.4GHz.

NOTE

If your router is dual-band, you don't need to adjust anything because it can operate on both 2.4GHz and 5GHz frequencies.

- D) If the issue persists, move to step 3.

Step 3: Check the Router Signal Strength

- A) Connect other devices to the router to check the signal strength.

Signal Strength (dBm)	Qualifier
> -30	Excellent
-30 to -65	Vey Good
< -65	Bad

- B) If the signal is strong, restart the router.
- C) If the signal is weak, proceed to step 4.

Step 4: Analyze Wireless Environment

- A) Use Wi-Fi scanning software to check the wireless environment of the PV plant.
- B) If the signal is weak, relocate the router closer to the microinverters.
- C) If the issue persists, investigate for potential interference from nearby wireless networks.
- D) If the signal is weak, proceed to step 5.

Step 5: Address Interference

- A) Adjust the router to a different Wi-Fi channel to mitigate interference.
- B) If the signal is weak, proceed to step 6.

Step 6: Contact the network operator to inquire about network problems.

Step 7: Consider adding a Wi-Fi booster to the network if the signal remains weak.

Step 8: If the problem persists, contact the installer for further assistance.

6.5 On-Site Inspection and Maintenance Instructions (Only for Qualified Technicians)

⚠ DANGER!

- Always wear personal protective equipment while performing inspection and maintenance.
- Shut down the microinverter and disconnect it from all power sources before beginning maintenance.
- The microinverter still contains lethal voltages after disconnecting from the power sources. Wait at least five minutes before proceeding with maintenance.

⚠ WARNING!

- Maintenance operations are strictly limited to authorized personnel, who are then responsible for reporting any discrepancies.

On-Site Inspection

Most microinverter faults can be diagnosed and resolved using the following troubleshooting steps.

Check Item	Method
Ambient Temperature	Check the temperature of the microinverter for overheating (see " Technical Data ").
Electrical Parameters	Verify the PV modules' DC voltage, the grid voltage, and the grid frequency is within the allowable range (see " Technical Data ").
Electrical Connection	Ensure every AC breaker is operational and locked in the closed position.
DC Connections	<p>Check and make sure the DC connection between the PV module and the microinverter is tight and secure.</p> <p>Check steps:</p> <ol style="list-style-type: none"> Disconnect the AC power first to de-energize the microinverter. Disconnect the DC connections. Re-connect the PV module and microinverter. If the DC connection is normal, the LED indicator will flash red.
AC Connections	<p>Check and make sure the AC connection between the grid and the microinverter is tight and secure. If DC connections and AC connections are functioning properly, the LED indicator will flash green.</p> <p>Check steps:</p> <ol style="list-style-type: none"> Disconnect the AC power first to de-energize the microinverter. Disconnect the DC connections. Re-connect the PV module and microinverter. If the DC connection is normal, the LED indicator will flash red. Reconnect the AC power. If DC and AC connections are normal, the LED indicator will flash green five times. If the problem persists, contact the Hoymiles Technical Support Team at service@hoymiles.com.

Maintenance

Regular inverter maintenance is essential for ensuring longevity and optimal performance assets. The checklist provides specific tasks for the maintenance process.

Check Item	Acceptance Criteria
Ventilation	<ul style="list-style-type: none"> • Verify the installation location has sufficient free space for ventilation and heat dissipation. • Keep all components free and clear of debris, especially around the heat sink. Clean the microinverter regularly using a soft brush or vacuum cleaner.
Electrical Connection	<ul style="list-style-type: none"> • Check the wiring connections for any loose or damaged wires. If needed, tighten any loose connections.
Microinverter Status	<ul style="list-style-type: none"> • Check the microinverter for any sign of corrosion or physical damage. Broken parts should be addressed immediately. • Regularly updating the firmware and software of the microinverters.
Environment	<ul style="list-style-type: none"> • Check and ensure the environmental conditions remain within the specified operating range (see "Technical Data").

7 Decommission

This section introduces how to safely remove, replace, store, and recycle microinverters at the end of their lifespan.

DANGER!

- Never disconnect a DC connector when PV modules are in the sun. Cover the PV modules before disconnecting.
- Potentially dangerous voltage may still be present inside disconnected microinverters.
- Disposal of the microinverter must comply with the related local regulations to avoid pollution. The microinverter must not be disposed of with normal waste.
- Do not make repairs yourself. Hoymiles microinverter does not have any user-serviceable parts inside.

7.1 Removing the Microinverter

Procedure

Step 1: Switch all AC circuit breakers to the **OFF** position.

Step 2: Use an electric meter or current clamp to ensure there is no voltage and current.

Step 3: Use the HMS Disconnect Tool to disconnect all AC connections and wait about five minutes.

Step 4: Use the HMS Disconnect Tool to disconnect all DC cable connections.

NOTE

To use the HMS Disconnect Tool,

- Align the HMS Disconnect Tool's notches with the released tabs on the connectors.
- Squeeze the tool firmly to apply pressure to the release tabs.
- Gently pull the connectors apart to disconnect them.

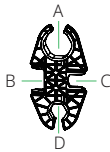

- Tighten/Loosen nuts
- Open the locking device
- Open the locking device
- Tighten/Loosen nuts

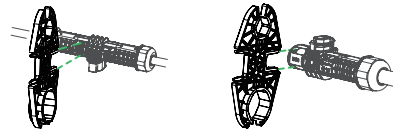

Step 5: Remove the PV modules from their mounts and cover them.

Step 6: Remove protective earthing connections (if needed).

Step 7: Unscrew the fixing screws on the top of the microinverter and remove the microinverter from the mounting racking.

7.2 Replacing the Microinverter

Procedure

Step 1: Record the new microinverter's SN.

Step 2: Switch all AC circuit breakers to the **OFF** position and wait about five minutes.

Step 3: Install the new microinverter. (See "[Installation Steps](#)".)

Step 4: Replace the microinverter in the monitoring platform.

- Log in to the S-Miles Cloud at <https://global.hoymiles.com>.
- Go to **O&M > Micro > Search**, locate the device you wish to replace, and click the **Device Maintenance** icon.

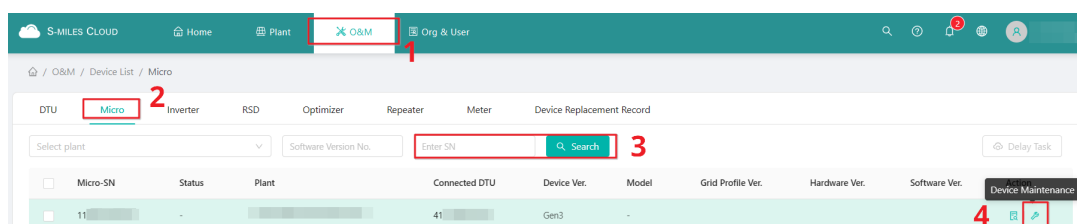

C) On the Device Maintenance dialogue, click **Replace Device**.

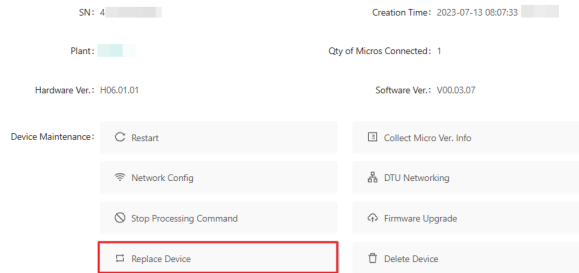

D) Enter the new microinverter's SN, then click **Confirm** to replace the microinverter.

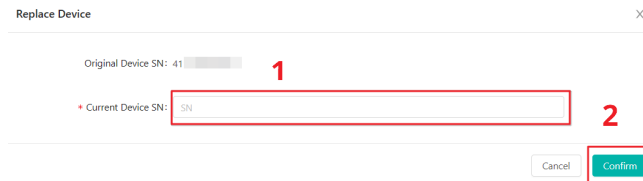

7.3 Storing and Transporting the Microinverter

The following requirements should be met if the microinverter is not put into use directly.

- Pack the microinverter in the original packaging. If the original packaging is unavailable, use the packaging that is suitable for the weight and dimensions of the microinverter.
- Maintain a storage temperature of -40°C to 85°C, and a relative humidity between 30% to 90%.
- Store the equipment indoors in a well-ventilated area.
- Protect the microinverter from physical shocks or vibrations during transportation and storage.
- Prevent sudden impacts or movements during transportation.
- Follow general transportation regulations for the mode of transport and ensure compliance with all local regulations.
- Conduct a thorough inspection before restarting the equipment after prolonged non-operation.
- Do not exceed the stacking limit marked on the outer side of the packaging.

7.4 Disposing of the Microinverter

Procedure

Step 1: Pack the microinverter in the original packaging. If the original packaging is unavailable, use the packaging that is suitable for the weight and dimensions of the microinverter.

Step 2: Properly seal the package using adhesive tape.

Step 3: Discard the packaging in accordance with local regulations.

8 Technical Data

⚠ WARNING!

Be sure to verify the following before installing Hoymiles Microinverter System.

- Verify that the PV module voltage and current specifications are compatible with the microinverter.
 - ▷ Make sure that the maximum open circuit voltage of the PV module is within the microinverter's operating voltage range.
- The PV module output DC power should not exceed 1.35 times the microinverter's output AC power. Refer to the Hoymiles Warranty Terms & Conditions for details.



Model	HMS-300W-1T	HMS-350W-1T	HMS-400W-1T	HMS-450W-1T	HMS-500W-1T
Input Data (DC)					
Commonly used module power (W)	240 to 405+	280 to 470+	320 to 540+	360 to 600+	400 to 670+
Maximum input voltage (V)	60	60	65	65	65
MPPT voltage range (V)	16-60				
Min./Max. start voltage (V)	22/60				
Maximum input current (A)	12	13	14	15	16
Maximum input short circuit current (A)	20	20	25	25	25
Number of MPPTs	2				
Number of inputs per MPPT	1				
Output Data (AC)					
Rated output power (VA)	300	350	400	450	500
Rated output current (A)	1.30	1.52	1.74	1.96	2.17
Nominal output voltage/range (V)*	230/180-275				
Nominal frequency/range (Hz)*	50/45-55				
Adjustable power factor (@nominal power)	>0.99 default 0.8 leading ... 0.8 lagging				
Number of microinverter per 2.5 mm ² line**	18	15	13	12	11
Total harmonic distortion (@nominal power)	<3%				
HMS Plug and Play Cable (Optional)					
Connector type	HMS Field Connector				
Cable size	1.5 mm ²				
Cable length	5 m (Customizable)				
Plug type	Schuko				
Efficiency					
CEC peak efficiency	96.70%	96.70%	96.70%	96.50%	96.50%
Nominal MPPT efficiency	99.80%				
Night power consumption (mW)	< 50				
Mechanical Data					
Ambient temperature range (°C)	-40 to +65				
Storage temperature range (°C)	-40 to +85				
Dimensions (W × H × D [mm])	182 × 164 × 30				
Weight (kg)	1.75				
Enclosure rating	Outdoor - IP67				
Cooling	Natural convection - No fans				
Features					
Communication	Built-in Wi-Fi				
Topology	Galvanically Isolated HF Transformer				
Monitoring	Toolkit or S-Miles Cloud				
Compliance	VDE-AR-N 4105: 2018, EN 50549-1: 2019, VFR 2019, IEC/EN 62109-1/-2, IEC/EN 61000-6-1/-2/-3/-4, IEC/EN 61000-3-2/-3				

* : Nominal voltage/frequency range can vary depending on local requirements.

** : Refer to local requirements for exact number of microinverters per AC output line.

9 Installation Map

To sheet _____ ↑

 <p>Please Make N for North</p> 		Panel type: Azimuth: Tilt: Sheet _____ of _____		Customer Information:													
		1	2	3	4	5	6	7	8	9	10	11	12	13	14	15	16
A	B	C	D														

↓ To sheet _____

To sheet _____ ↓

↑ To sheet _____

